

STEREO TAPE RECORDER

MODEL 1722W

ALSO APPLICABLE TO MODEL 1722L
STEREO TAPE RECORDER

SECTION 1	SERVICE MANUAL	3
SECTION 2	PARTS LIST	21
SECTION 3	SCHEMATIC DIAGRAM	40

1

2

SECTION 1

SERVICE MANUAL

TABLE OF CONTENTS

I.	SPECIFICATIONS	4
II.	MEASURING METHOD	6
	1. TAPE SPEED DEVIATION	6
	2. WOW AND FLUTTER	6
	3. FREQUENCY RESPONSE	6
	4. SIGNAL TO NOISE RATIO	6
	5. TOTAL HARMONIC DISTORTION FACTOR	7
	6. CROSS TALK (Cross talk between the tracks)	7
	7. ERASE RATIO	7
	8. POWER OUTPUT	7
III.	DISMANTLING OF UNIT	8
IV.	MECHANISM ADJUSTMENT	9
	1. PINCH WHEEL ADJUSTMENT	9
	2. SUPPLY REEL TABLE TENSION ADJUSTMENT	11
	3. TAKE UP REEL TABLE TENSION ADJUSTMENT	11
	4. FWD/REC MODE MECHANISM CHANGE AND ADJUSTMENT	12
	5. DRIVE BELT POSITION ADJUSTMENT	12
	6. FLYWHEEL LOOSE PLAY ADJUSTMENT	12
	7. ADJUSTMENT OF IDLER #2 POSITION AT FAST FORWARD MODE	14
	8. AUTOMATIC SHUT-OFF OPERATING POINT ADJUSTMENT	14
V.	HEAD HEIGHT ADJUSTMENT	15
	1. HEAD HEIGHT ADJUSTMENT	15
	2. HEAD SLANT ADJUSTMENT	15
	3. RECORDING/PLAYBACK HEAD AZIMUTH ALIGNMENT ADJUSTMENT	16
VI.	AMPLIFIER	17
	1. RECORDING BIAS FREQUENCY CHECK	17
	2. FREQUENCY RESPONSE CHECK	17
	3. RECORDING BIAS VOLTAGE CHECK	17
	4. ERASE VOLTAGE	17
	5. HUM ALLEVIATION COIL ADJUSTMENT	17
VII.	D.C. RESISTANCE OF VARIOUS COILS	18
VIII.	COMPOSITE VIEWS OF COMPONENTS	19

I. SPECIFICATIONS

An asterisk next to a figure indicates the minimum guaranteed performance.

TRACK SYSTEM	4-track 2-channel stereo/monaural system.
REEL CAPACITY	Up to 7" reel
TAPE SPEED	7-1/2 and 3-3/4 ips. $\pm 2\%$ (* $\pm 3\%$)
WOW AND FLUTTER	Less than 0.14% (*0.15%) R.M.S. at 7-1/2 ips. Less than 0.18% (*0.20%) R.M.S. at 3-3/4 ips.
TOTAL WOW AND FLUTTER	Less than 0.22% R.M.S. at 7-1/2 ips. (Scotch #175 TAPE 3,000 Hz recording and playback)
FREQUENCY RESPONSE	1,000 Hz -16VU Recording, measured at speaker output
WIDE RANGE TAPE	30 to 21,000 Hz (*50 to 20,000 Hz) ± 3 dB at 7-1/2 ips. 40 to 15,000 Hz (*50 to 12,000 Hz) ± 3 dB at 3-3/4 ips.
LOW NOISE TAPE	30 to 18,000 Hz (*50 to 18,000 Hz) ± 3 dB at 7-1/2 ips. 40 to 13,000 Hz (*50 to 10,000 Hz) ± 3 dB at 3-3/4 ips.
DISTORTION FACTOR	Less than 2% at 7-1/2 ips.
TOTAL DISTORTION FACTOR	Less than 3% at 1,000 Hz "0" VU recording at 4 mV mic Input, Output 2W and Tone Control Max using Scotch #211
SIGNAL TO NOISE RATIO	Better than 50 dB (*47 dB) at 10 dBm output and Tone Control Max (from Speaker Out)
TOTAL SIGNAL TO NOISE RATIO	Better than 43 dB at 10 dBm output and Tone Control Max. (from Speaker Out)
CROSS TALK	Better than 60 dB (*55 dB) Monaural (Mic input 4 mV, 1,000 Hz +3 VU recording, measured at line output) Better than 45 dB (*43 dB) Stereo (mic input 4 mV, 1,000 Hz +3 VU recording, measured at line output)
ERASE RATIO	Better than 70 dB (*65 dB) 1,000 Hz +3 VU recording
INPUTS	Volume at maximum, 1,000 Hz "0" VU indication
MIC INPUT	More than 0.5 mV
LINE INPUT	More than 70 mV
DIN INPUT	More than 70 mV (High) More than 5 mV (Low)
OUTPUTS	OV (volume min) to 2.3V (volume max) using a 250 Hz "0" VU pre-recorded tape at 7-1/2 ips.
DIN OUTPUT	1V
PHONE OUTPUT	100 mV at 8 Ω each CH.
SPEAKER OUTPUT	3W/8 Ω each CH. *More than (2W/2W) continuous power at 8 Ω
RECORDING BIAS FREQUENCY	63 kHz $\pm 8\%$
BIAS LEAK	Less than -20 VU measured at line output
HIGH FREQUENCY DEVIATION	With 2 dB using an 8,000 Hz 3-3/4 ips. pre-recorded tape at 7-1/2 ips. Tone Control Max
RECORDING CAPACITY	2 hours stereo recording using a 1,200 ft. tape at 3-3/4 ips
FAST FOWARD AND REWIND TIME	80/100 sec. using a 1,200ft. tape at 60/50 Hz
MOTOR	2-4 pole induction 2-speed motor. type: IC-16Y Revolutions: 1,790/1,490 r.p.m. at 60/50 Hz (Low Speed) 3,580/2,980 r.p.m. at 60/50 Hz (High Speed)
HEADS	RECORDING/PLAYBACK HEAD
	Type: P4-150 Gap: 2 microns Impedance: 1,250 $\Omega \pm 15\%$ at 1,000 Hz D.C. Resistance: 91 Ω
	ERASE HEAD
	Type: E4-200 Gap: 0.6 mm Impedance: 200 $\Omega \pm 5\%$ at 100 kHz D.C. Resistance: 2 Ω

TRANSISTORS	2SC458LG(B) (C) . . . 4 2SC711 (D) (E) . . . 4 2SC968 (3) (Red) . . . 2	2SC1013 (D) . . . 4 2SC1312 (F) (G) . . . 2
DIODES	1N34A . . . 2	10DC-1 (Blk) . . . 1 10DC-1 (Red) . . . 2
SPEAKERS	2 built in (5" x 7") Oval speakers Impedance: 8 Ω	
POWER SUPPLY	100 to 240V A.C. 50/60 Hz 120V A.C. 60 Hz for CSA/UL Models 220V A.C. 50 Hz for CEE Models	
POWER CONSUMPTION	50W	
DIMENSIONS	1722W	358(W) x 360(H) x 248 (D)mm (14" x 14.1" x 9.8")
	1722L	359(W) x 366(H) x 248 (D)mm (14.1" x 14.4" x 9.8")
WEIGHT	1722W	13.2 kg (29 lbs.)
	1722L	14.0 kg (30.8 lbs.)

NOTE: Specifications subject to change without notice.

II. MEASURING METHOD

1. TAPE SPEED DEVIATION

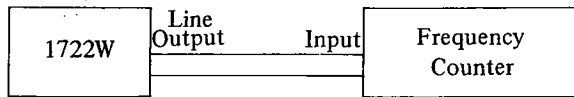

Fig. 1

As shown in Figure 1, connect a Frequency Counter to the Line Output of the recorder. Take a frequency counter reading at the beginning, middle, and end of tape winding during playback. The maximum value of these respective readings will represent tape speed deviation.

2. WOW AND FLUTTER

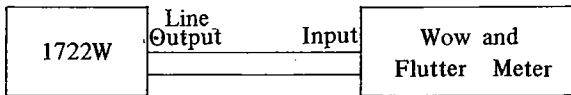

Fig. 2

Method A

As shown in Fig. 2, connect the Line Output of the recorder to the Input of a Wow and Flutter Meter. Use a 3,000 Hz pre-recorded test tape and take a wow and flutter meter reading at the beginning, middle, and end of tape winding. The maximum value of these respective readings will represent the wow and flutter.

Method B

Supply a 3,000 Hz sine wave signal from an Audio Frequency Oscillator and make a recording on a blank tape at the beginning, middle, and end of tape winding. Rewind and playback tape. Measure wow and flutter with a Wow and Flutter Meter. (The wow and flutter value of Method B will be close to $\sqrt{2}$ times of Method A)

3. FREQUENCY RESPONSE

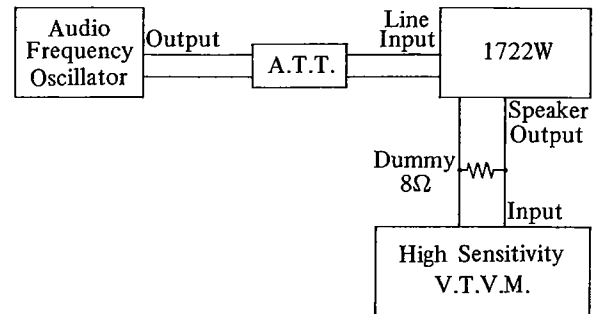

Fig. 3

- 1) Connect the various instruments as shown in Fig. 3 and supply a 1,000 Hz sine wave signal to the Line Input of the recorder from an Audio Frequency Oscillator through an Attenuator. Set recorder to "REC" mode and turn recording level control volume to obtain "0" VU meter reading.
- 2) Under conditions described in 1) above, readjust Attenuator so that the Line Input is -16 dB, and record 50 to 18,000 Hz spot frequencies.
- 3) Rewind tape and playback from the beginning. Take V.T.V.M. spot frequency readings and plot values on a graph.

NOTE: When measuring frequency response, new tape should be used.

4. SIGNAL TO NOISE RATIO

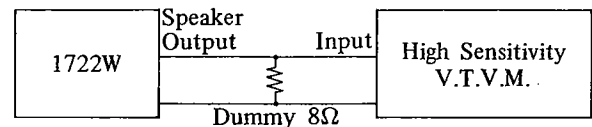

Fig. 4

Connect the various instruments as shown in Fig. 4 and playback a 250 Hz "0" VU pre-recorded test tape and adjust volume control to obtain +10 dbm V.T.V.M. reading. Then remove the tape and measure the noise level under the same condition. Convert each of the measured values into decibels.

5. TOTAL HARMONIC DISTORTION FACTOR

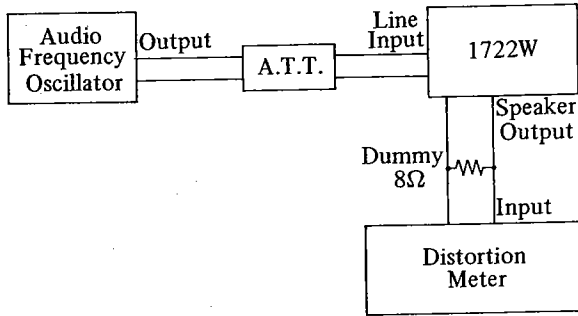

Fig. 5

- 1) Connect the various instruments as shown in Fig. 5. Load a Scotch #211 tape and set Tone control to "MAX" position.
- 2) Record a 1,000 Hz sine wave signal at "0" VU. Playback the resultant signal and measure the overall distortion factor.

NOTE: 1) At this time, Distortion factor of the Audio Frequency Oscillator must be sufficiently small.
2) When measuring the distortion factor, new tape should be used.

6. CROSS TALK (Cross talk between the tracks)

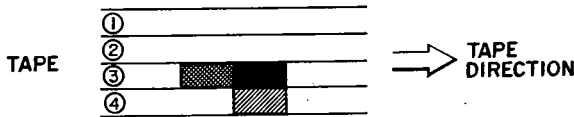

Fig. 6

As shown in Fig. 6, first record a 1,000 Hz sine wave signal on Track No.3 at +3 VU level. Next, record under a non-input condition. Then, playback the tape on Tracks No.3 and 4 through the B.P.F. (band pass filter sensitivity ... 1 : 1) and obtain a ratio between the two from the following formula:

$$C = 20 \log \frac{E_0}{E_2 - E_1} \text{ (dB)}$$

where,

- C = desired cross talk ratio (dB)
- E_0 = 1,000 Hz signal output level (V)
- E_2 = 1,000 Hz cross talk level (V)
- E_1 = Non-input signal recorded level (V)

7. ERASE RATIO

As shown in Fig. 4, connect a High Sensitivity V.T.V.M. to the Line Output of the recorder. Playback a virgin tape and take a V.T.V.M. reading of the output level. Next, record a 1,000 Hz sine wave signal at +3 dB, then playback this recorded signal and take a V.T.V.M. reading of the output level. Next, using this pre-recorded tape, record under a non-input condition and take a reading of the noise level output of the erased signal and obtain a ratio between the two from the following formula:

$$E_r = 20 \log \frac{E_0}{E_2 - E_1} \text{ (dB)}$$

where,

- E_r = Desired erase ratio (dB)
- E_0 = 1,000 Hz signal output level (V)
- E_2 = Non-input signal recorded level (V)
- E_1 = Virgin tape noise output level (V)

8. POWER OUTPUT

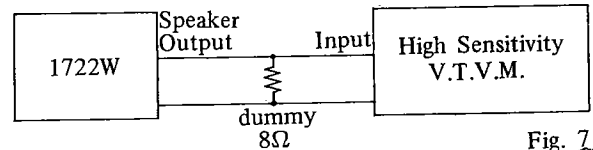

Fig. 7

As shown in Fig. 7, connect an 8Ω dummy load resistor to the speaker output of the recorder and connect this terminal to a High Sensitivity V.T.V.M. Playback a 250 Hz "0" VU pre-recorded test tape and take a V.T.V.M. reading of the output level. The resultant output can be obtained from the results of the above measurement by using the following formula:

$$P = \frac{E^2}{R} \text{ (W)}$$

where,

- P = Desired power output (watts)
- E = Measured voltage (V) (R.M.S.)
- R = 8Ω

III. DISMANTLING OF UNIT

In case of trouble, etc. necessitating disassembly, please disassemble in the order shown in photographs. Reassemble in reverse order.

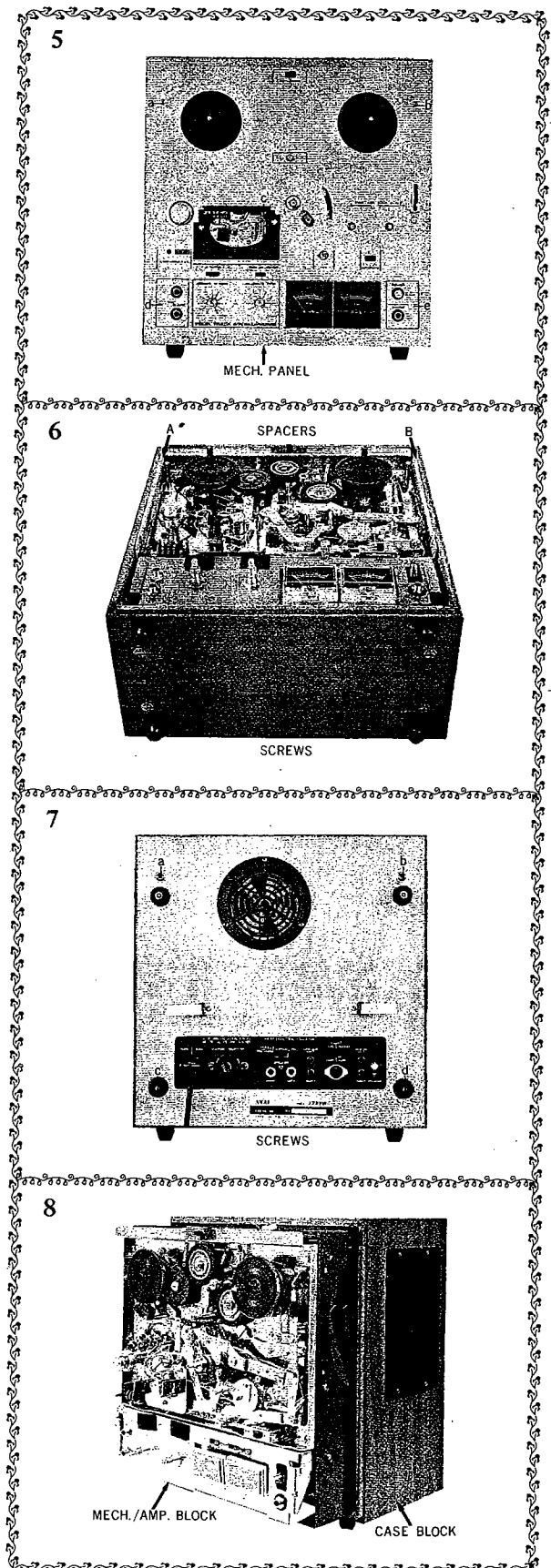
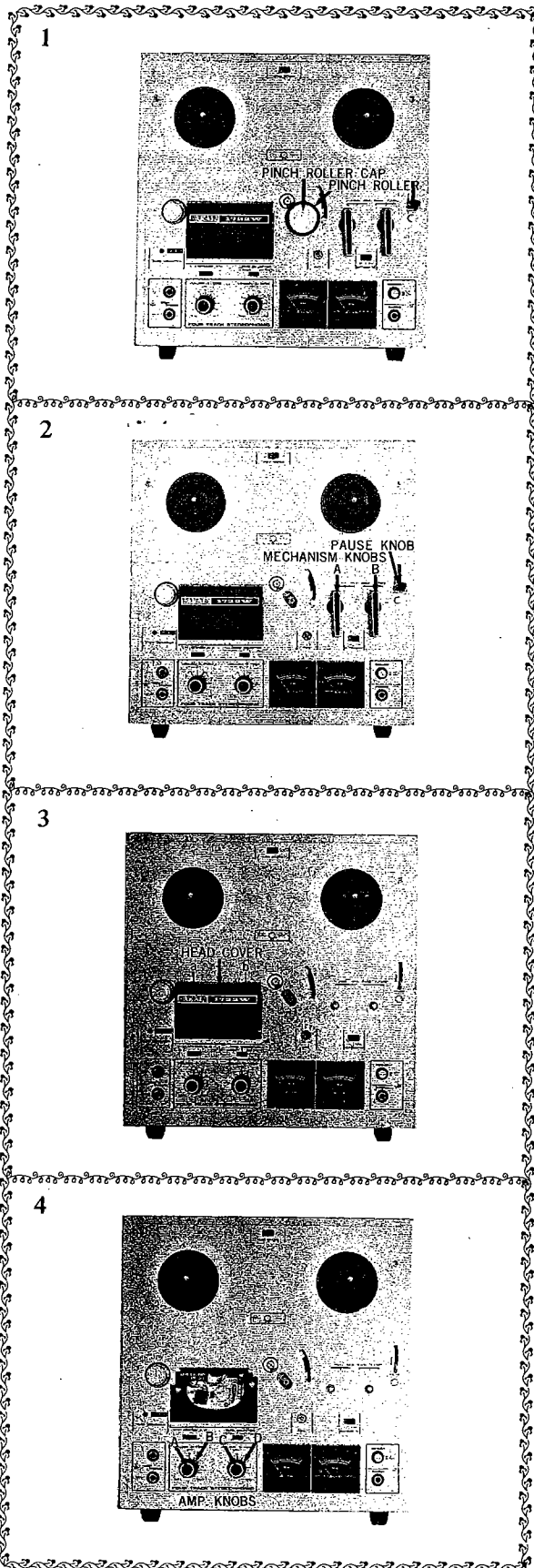

IV. MECHANISM ADJUSTMENT

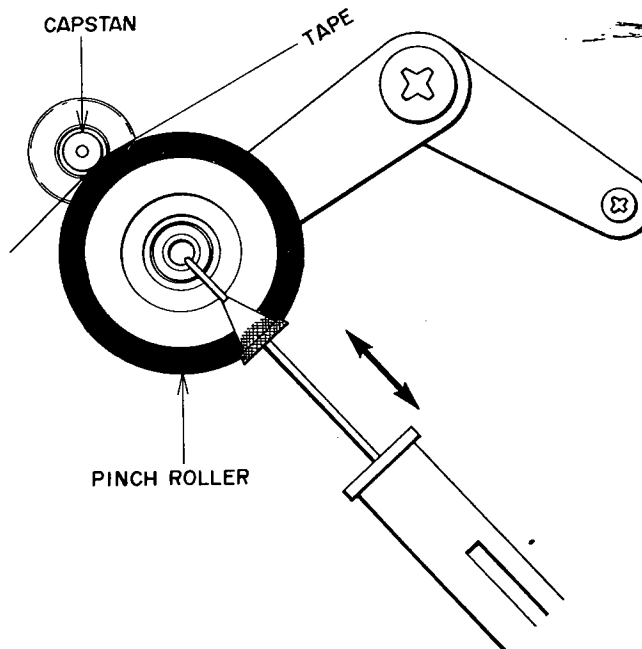

Fig. 8

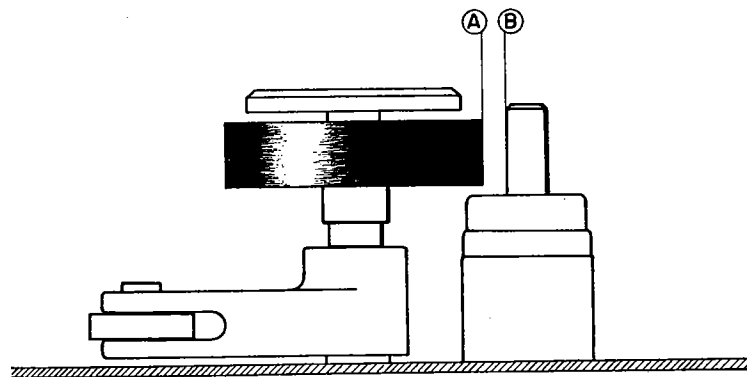

Fig. 9

1. PINCH WHEEL PRESSURE MEASUREMENT

(See Fig. 8)

Confirm the following prior to pinch wheel pressure measurement: (See Fig. 9)

The part of the pinch wheel over which the tape passes is parallel with the capstan shaft. (represented by **A** and **B** in Fig. 9)

- 1) As shown in Fig. 8, measure pinch wheel pressure with a spring gauge by pulling the pinch wheel away from the capstan and then returning. Take a reading of the spring gauge indication at the time the pinch wheel contacts the capstan. Correct pinch wheel pressure at this time is within 1,150 to 1,200 gr.

- 2) In case **A** and **B** in Fig. 9 is not parallel, check for the following.

- a. Rubber part of pinch wheel is worn. (Replace pinch wheel)
- b. Capstan or pinch wheel shaft is bent. (Adjust)

NOTE: This condition may also be caused by twisted tape or wow and flutter.

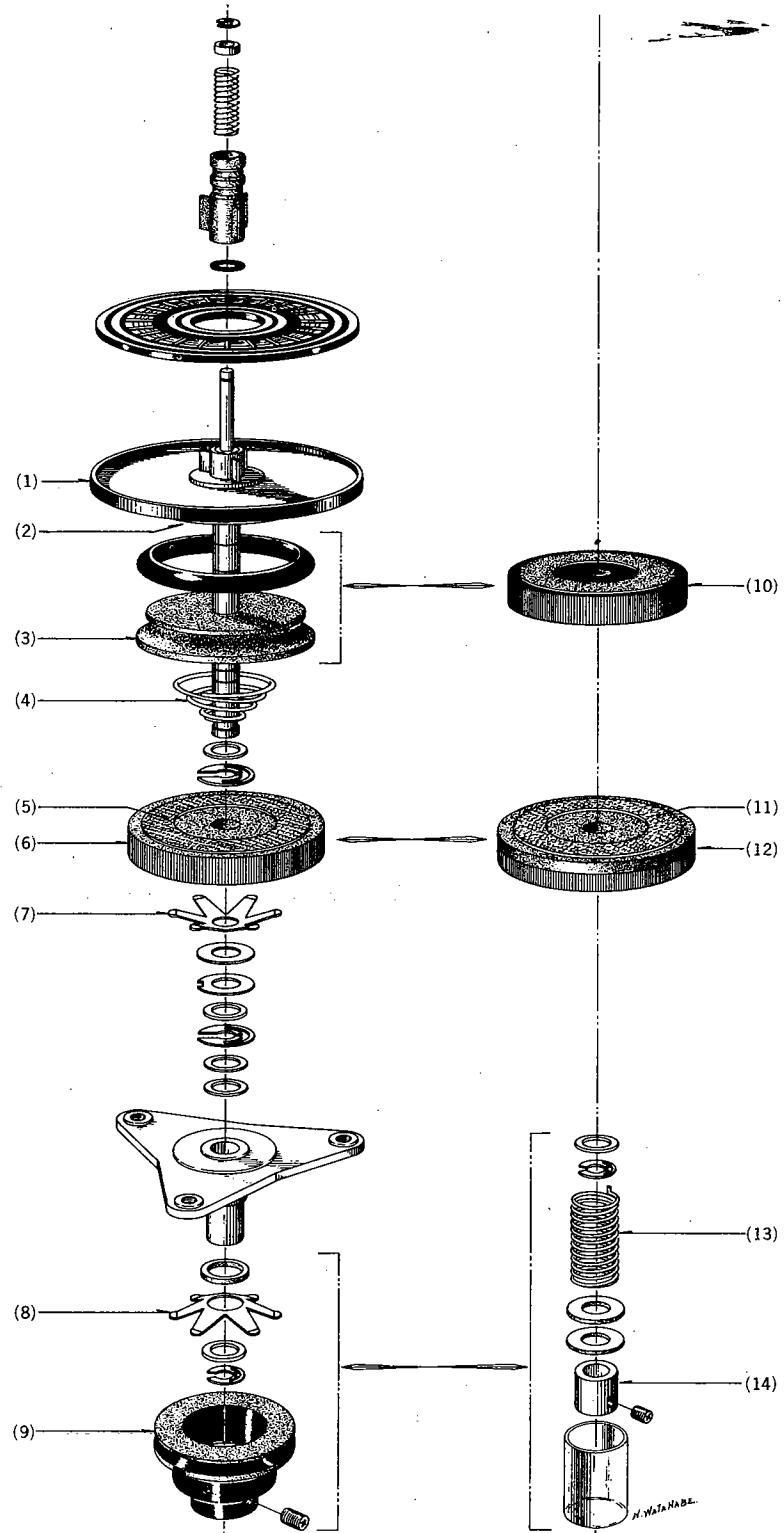

Fig. 10

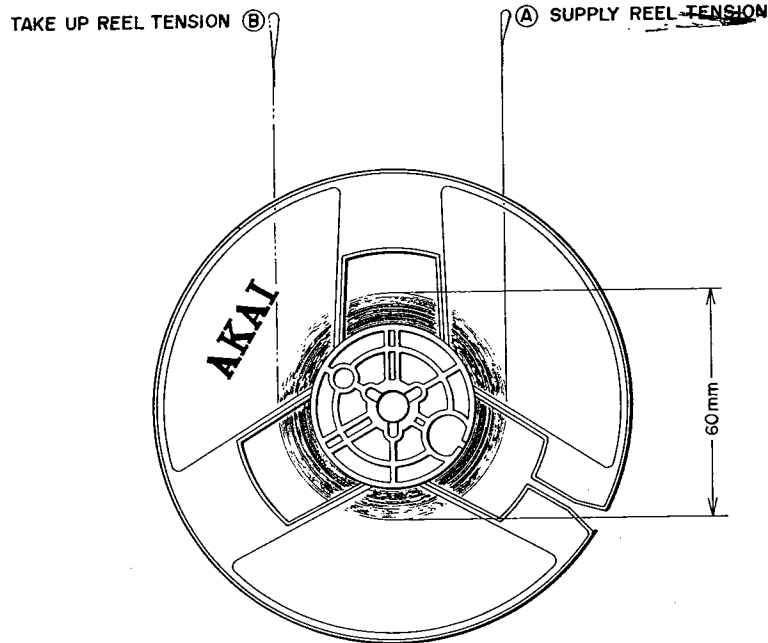

Fig. 11

2. SUPPLY REEL TABLE TENSION ADJUSTMENT (See Fig. 10 at left)

Clutch felt (2) is used on the bottom part of rewind pulley (3) and reel table base plate (1) to protect the tape from excessive tension at rewind mode.

For measuring the tension of each reel, it is ideal to use on empty 5" reel on which a tape has been wound to cover a 60 mm diameter as shown in Fig. 11.

Check and Adjustment (See Fig. 11- (A))

- (a) At rewind mode, the tension of felt (2) part shown in Fig. 10 should be from 400 to 500 grams when the tape is gently pulled upward with a spring gauge. If adjustment is necessary, this can be accomplished by increasing or decreasing the number of washers used.
- (b) Felt (5) is for the purpose of applying suitable clutch (back tension) at Forward and Recording modes. Measure in the same way as outlined in item (a) and adjust by strengthening or weakening the tension by increasing or decreasing the number of washers respectively to obtain 80 to 100 grams of tension.
- (c) At Fast Forward mode, the tension (free tension) should be 15 to 20 grams. To adjust, strengthen or weaken tension by increasing or decreasing the number of washers and by moving Pulley (9) up and down and tightening to fixed position with screw.

3. TAKE UP REEL TABLE TENSION ADJUSTMENT (See Fig. 10 at right)

Clutch felt (2) is used on the bottom of reel table base plate (1) for the purpose of preventing excessive tension from being applied to the tape and tape stretch from occurring at Fast Forward mode.

Check and Adjustment (See Fig. 11- (B))

- (a) To measure the tension between felt (2) and rewind roller A (10), load the tape and at forward mode, gently pull end of tape upward with a spring gauge (Fig. 11- (B)) Ideal tension at this part is 400 to 500 gr.
To adjust, increase or decrease the number of washers used. Also, if rotation is not smooth when turned by hand, replace felt.
- (b) Felt (11) on take up roller D (12) is for the purpose of clutch between take up roller A (10) and take up roller D. Measure the tension at this part in the same way as outlined in paragraph (a).
Ideal tension is 150 to 180 grams. Adjust by increasing or decreasing the number of washers used.
- (c) At Rewind mode the tension (free tension) should be 15 to 20 grams. Adjustment can be made by increasing or decreasing the number of washers used and by moving set sleeve B (14) up and down and repositioning.

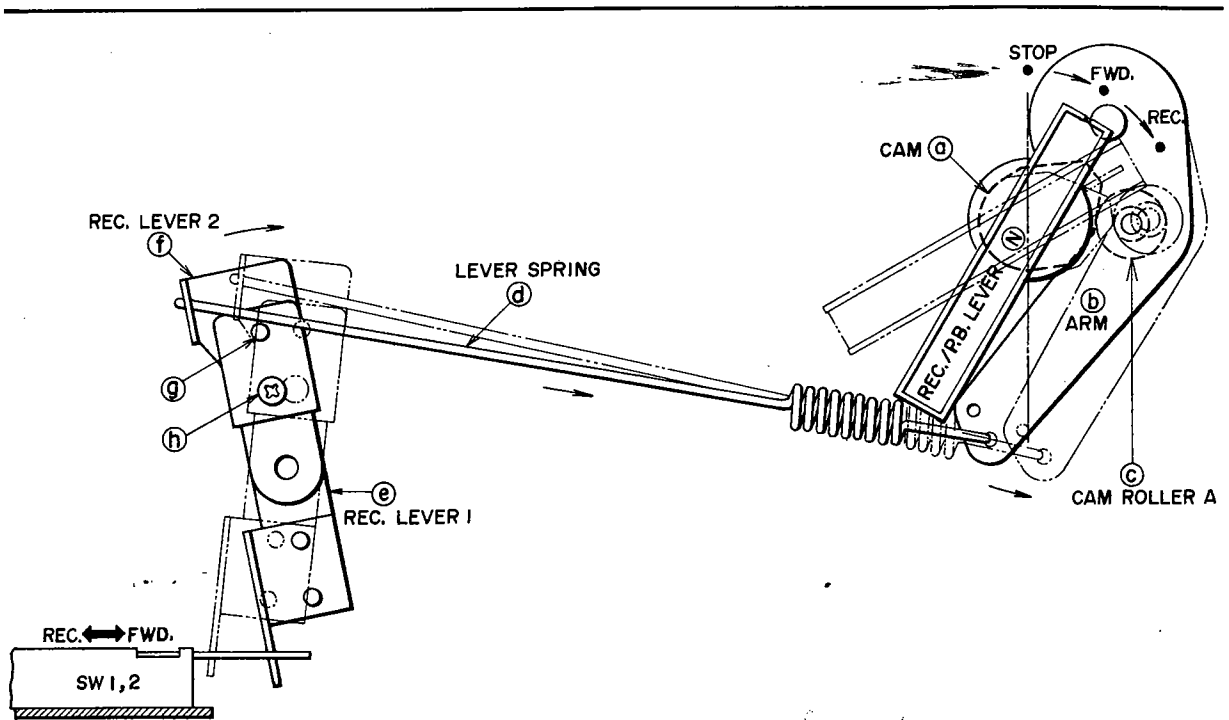

Fig. 12

4. FWD/REC MODE MECHANISM CHANGE AND ADJUSTMENT

OPERATION

- (1) Set REC/PLAY Lever from FWD to REC position.
- (2) Cam (a) pushes Cam Roller (c) and Arm (b) as illustrated by the dotted lines in Fig. 12.
- (3) Arm (b) pulls Lever Spring shaft (d) as indicated by the arrow mark.
- (4) Then, Recording Levers 1 and 2 ((e) and (f)) set Slide Switches SW-1 and SW-2 to recording condition.

In the event that the Recording Levers (REC LEVER 1 (e), REC LEVER 2 (f)) do not push the Slide Switches perfectly, too much loose play exists.

* Vibration or the inability to record is sometimes caused by imperfect slide switch operation.

Adjustment: Adjust position of Recording Levers 1 and 2 while checking to confirm that the levers are pushing the Slide Switches perfectly.

Fix at adjusted position with screws

(g) and (h)

5. DRIVE BELT POSITION ADJUSTMENT

If drive belt position adjustment is necessary, with the power turned ON, insert a U shaped washer in the place indicated in the figure so that the drive belt come to the center of the motor pulley as shown in Fig. 13.

6. FLYWHEEL LOOSE PLAY ADJUSTMENT

With a minus driver, turn bearing and adjust gap to obtain a 0.3 mm loose play between the Steel Ball and Bearing when the flywheel is moved as indicated by the arrow mark (↔) in Fig. 14.

Fix at ideal position by turning nut to right (see figure).

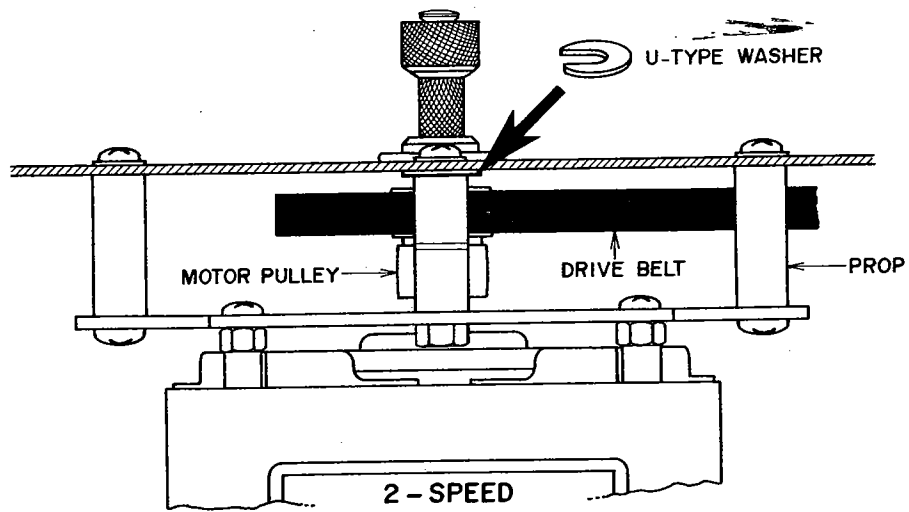

Fig. 13

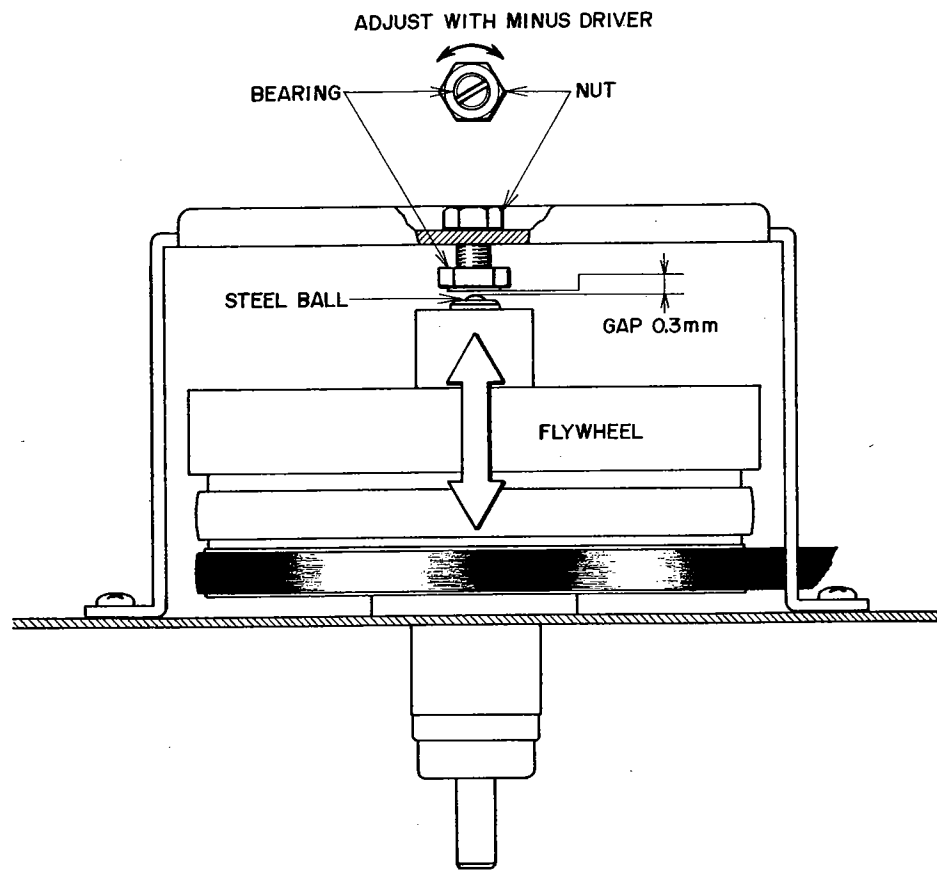

Fig. 14

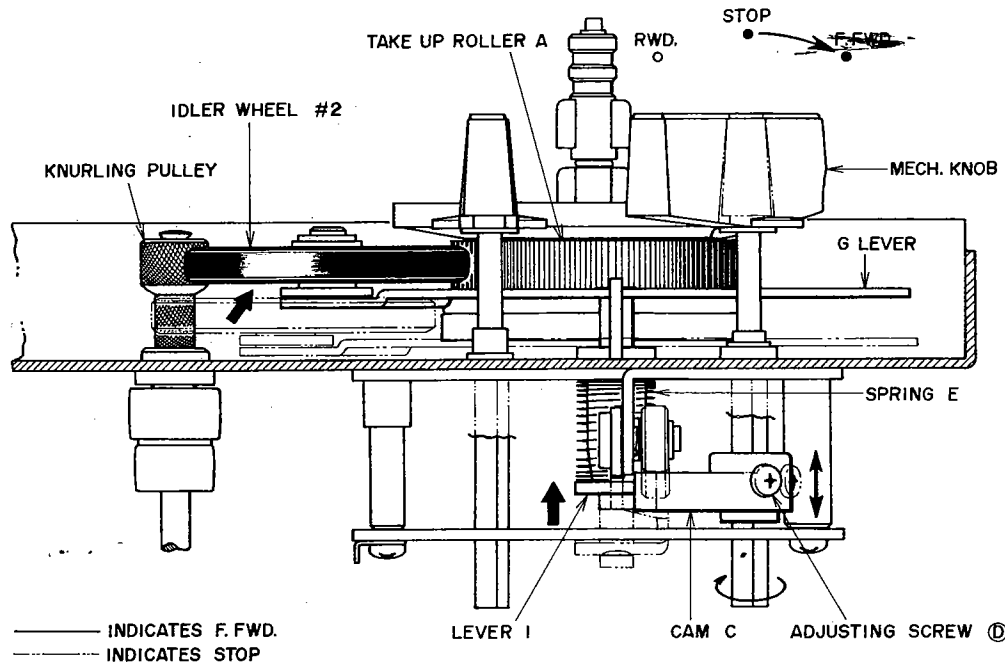

Fig. 15

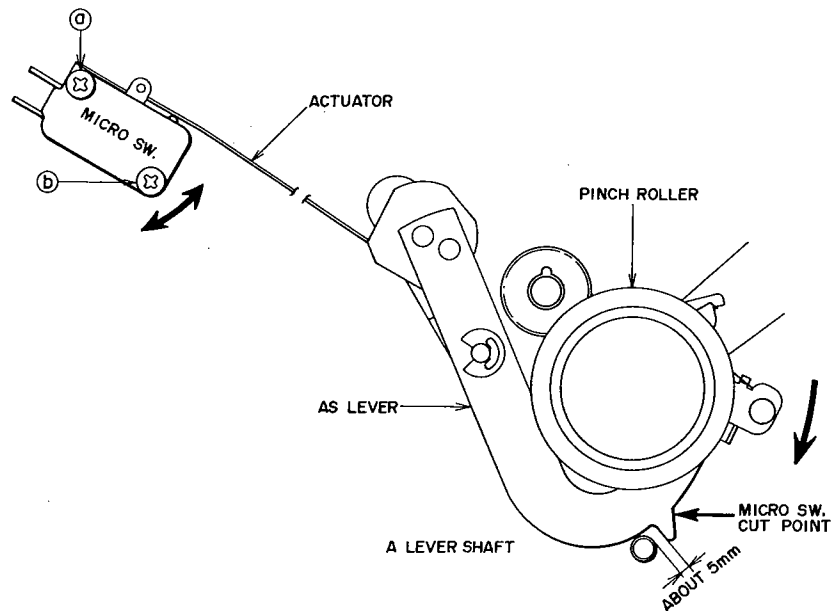

Fig. 16

7. ADJUSTMENT OF IDLER #2 POSITION AT FAST FORWARD MODE

Move Cam © shown in Fig. 15 up and down as indicated by the arrow mark (↔) in the figure and adjust Lever © height so that Idler #2 contact between Take Up Roller A and the knurling Pulley is uniform when the F.FWD/RWD Lever is set to F.FWD position. Fix at adjusted position with Adjustment Screw ©. During operation, confirm that the rotating position of Idler #2 is ideal.

8. AUTOMATIC SHUT-OFF OPERATING POINT ADJUSTMENT

Move Micro Switch as indicated by the arrow mark (↔) in the figure and fix Screws (a) and (b) so that when the Automatic Shut-off Switch is at ON position, the Micro Switch is perfectly turn off at position at which the gap between A lever shaft and AS lever Stopper is about 5 mm as shown in Fig. 16.

V. HEAD HEIGHT ADJUSTMENT

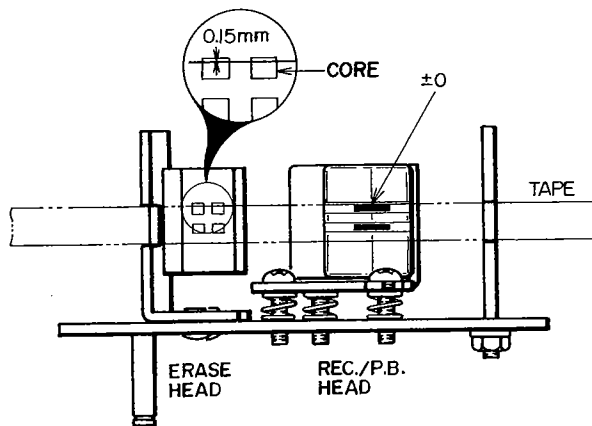
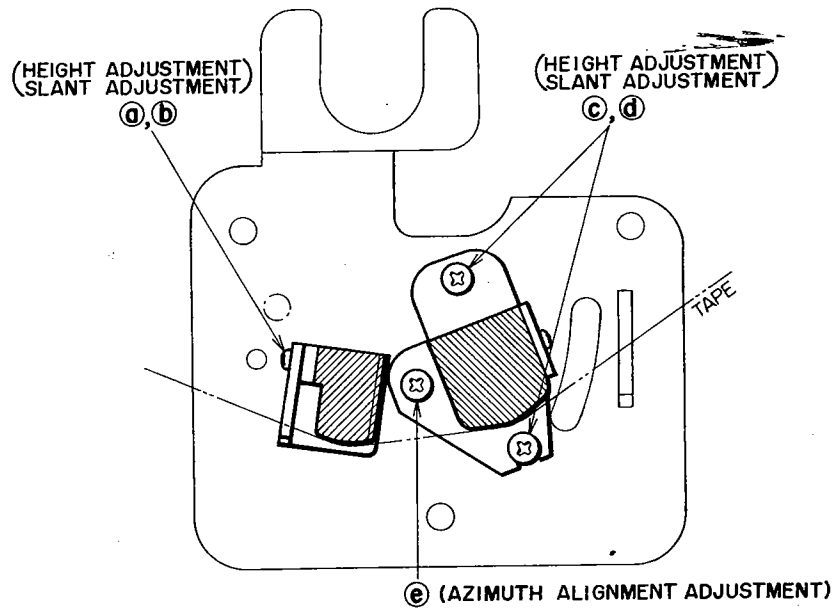

Fig. 17

As head adjustment is of utmost importance to the operation of a tape recorder, please be especially careful in making these adjustments. Also please check the tape travel system.

If the tape travel system is faulty, because this causes the tape to twist, etc., be sure that reel height adjustment is precise.

2. HEAD SLANT ADJUSTMENT (See Fig. 17)

Adjust Adjustment Screws (a), (b), (c), and (d) so that the erase and recording/playback heads contact the tape at the proper angle in relation to tape travel.

1. HEAD HEIGHT ADJUSTMENT

1) Erase Head

Loosen Screws (a) and (b) and adjust the erase head height. Tighten screws. At position at which the upper edge of the tape is 0.15 mm lower than the upper edge of the erase head core.

2) Recording/Playback Head

Adjust with Head Height Adjustment Screws (c) and (d) so that the upper edge of the tape and the upper edge of channel 1 head core are the same height.

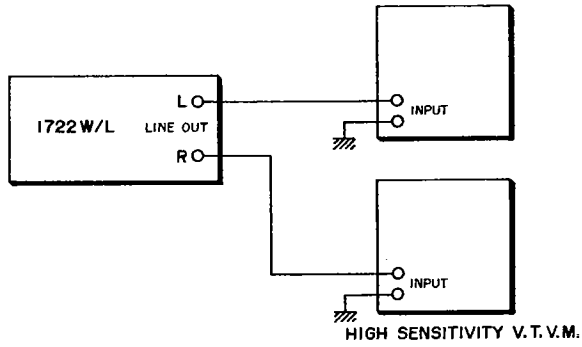

Fig. 18

3. RECORDING/PLAYBACK HEAD AZIMUTH ALIGNMENT ADJUSTMENT (See Figs. 17 and 18)

- 1) Playback an Ampex Alignment Test Tape (8,000 Hz, 3-3/4 ips recorded) at 7-1/2 ips.
- 2) Connect a High Sensitivity V.T.V.M. to the line output ~~input~~ as shown in Fig. 18 and adjust Screw (e) to obtain maximum V.T.V.M. indication at -10 dBm range.
- 3) Repeat Items 1 through 3 two or three times for optimum performance.

VI. AMPLIFIER

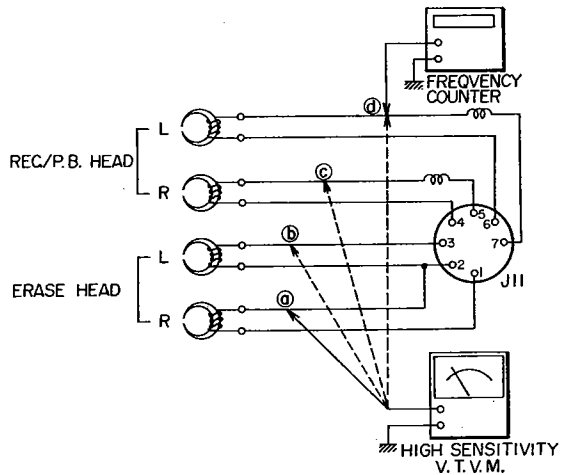

Fig. 19

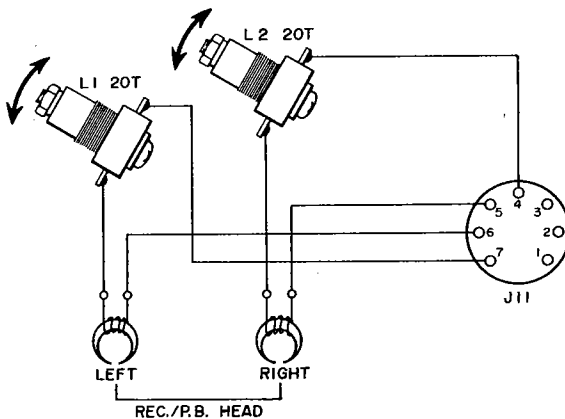

Fig. 20

Connect the various measuring instruments as shown in Fig. 19.

1. RECORDING BIAS FREQUENCY CHECK (See Fig. 19)

- 1) Set recorder to recording mode.
 - 2) Connect a Frequency Counter to point (d) of the Recording/Playback Head as shown in Fig. 19 and read indication.
- * Specified recording bias frequency is $63 \text{ kHz} \pm 8\%$.

2. FREQUENCY RESPONSE CHECK

- 1) For measuring instrument connections, see Fig. 3. Set recorder to recording mode and supply a 1,000 Hz sine wave signal to the line input from an Audio Frequency Oscillator. Record at 1,000 Hz -16 VU and then switch the Oscillation frequency of the Audio Frequency Oscillator to 10,000 Hz and record.
- 2) The Volume Controls must be set to obtain a VU meter indication of -16VU at 1,000 Hz. The Tone Controls should be set to maximum for 3-3/4 ips. tape speed and to about 4 or 5 position for 7-1/2 ips. tape speed.
- 3) The V.T.V.M. indication should display equally flat frequency response at the two frequencies in items 1) and 2) (both channels).

3. RECORDING BIAS VOLTAGE CHECK

Check the voltage at points (c) and (d) shown in Fig. 19.
Correct recording bias voltage is about 13V A.C.

4. ERASE VOLTAGE

Correct erase voltage is about 43.5V A.C.

5. HUM ALLEVIATOR COIL ADJUSTMENT

(Refer to Fig. 4 of Measuring Method)

Connect a High Sensitivity V.T.V.M. to the Speaker output Terminal through an 8Ω dummy load resistor, ~~Load a 250 Hz "0" VU recorded test tape~~ and set Tone Controls to Maximum. Playback the test tape and move hum alleviator coils as indicated by the arrow marks in Fig. 20 while observing V.T.V.M. indication and position at place where V.T.V.M. indication is minimum. (Must be better than 47 dB).

VII. D. C. RESISTANCE OF VARIOUS COILS

D.C. resistance value is average value.

Designation	Type	D.C. Resistance
Main Motor	IC-16Y	Between Red-Vlt 100Ω Between Gry-Vlt 80Ω Between Wht-Blk 140Ω Between Ylw-Blk 310Ω
Driver Transformer	N24-6847 AT	Primary 150Ω Secondary 70Ω
Oscillation Coil	OT-204	Between 1-3 0.3Ω Between 4-6 0.7Ω Between 7-9 8.2Ω
Erase Head	E4-200	2Ω
Recording/Playback Head	P4-150	91Ω
Hum Alleviator Coil	20T	0.5Ω
Power Transformer	LST-1	(Refer to diagram shown below)

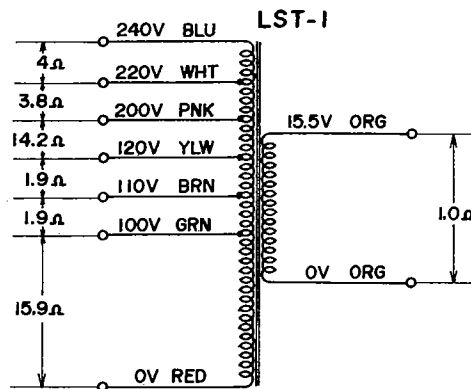
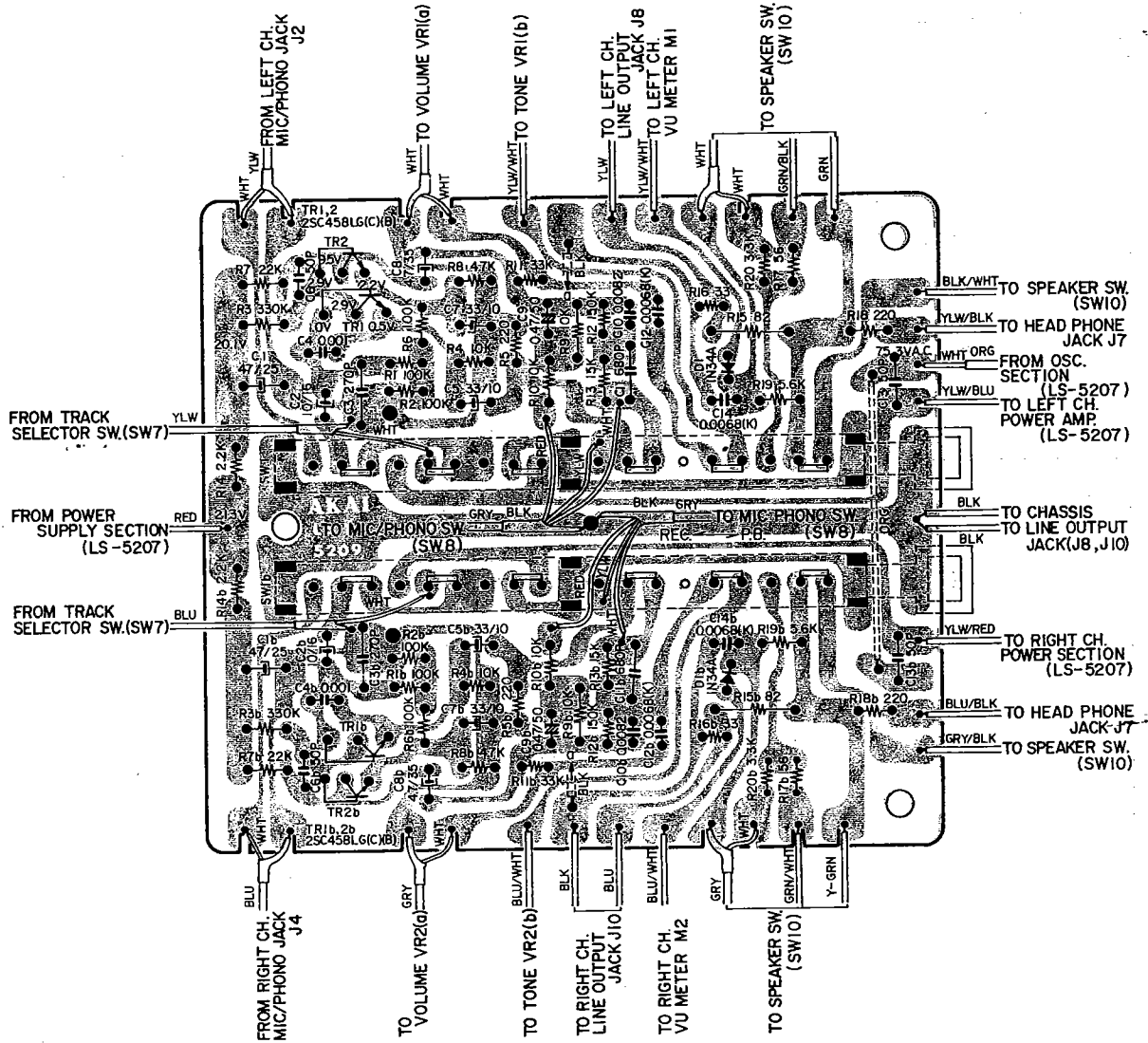

Fig. 21

VIII. COMPOSITE VIEWS OF COMPONENTS

I. PRE-AMP. P.C. BOARD (LS-5209)



2. MAIN AMP./OSC./POWER SUPPLY P.C. BOARD (LS-5207)

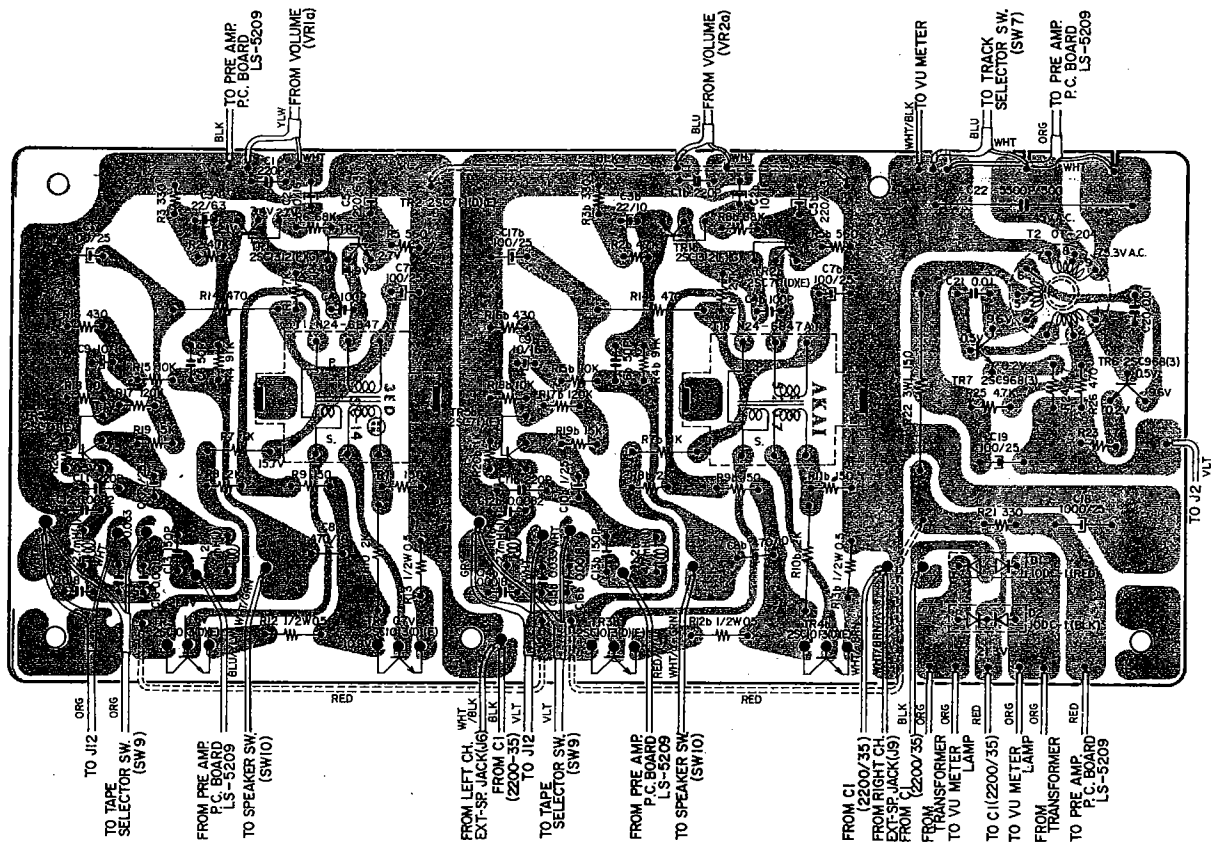

SECTION 2

PARTS LIST

TABLE OF CONTENTS

FIG. 1	HEAD BLOCK	24
FIG. 2	REEL TABLE BLOCK	25
FIG. 3	MOTOR/BELT CHANGE LEVER BLOCK	26
FIG. 4	FLYWHEEL BLOCK	28
FIG. 5	SWITCH BLOCK	29
FIG. 6	MECH. ASSEMBLY BLOCK	30
FIG. 7	PRE-AMP. P.C. BOARD (LS-5209) BLOCK	32
FIG. 8	MAIN AMP./OSC./POWER SUPPLY P.C. BOARD (LS-5207) BLOCK	33
FIG. 9	AMP. ASSEMBLY BLOCK	34
FIG. 10	FINAL ASSEMBLY BLOCK	36
INDEX		38

HOW TO USE THIS PARTS LIST

1. This parts list is compiled by various individual blocks based on assembly process.
2. When ordering parts, please describe parts number, serial number, and model number in detail.
3. How to read list.

The reference number corresponds with illustration or photo number of that particular parts list.

This number corresponds with the Figure Number.

This number corresponds with the individual parts index number in that figure.

A small "x" indicates the inability to show that particular part in the Photo or Illustration.

12-115x

Schematic Diagram Number of individual manufactured part.







(not required for parts order)

Quantity of particular part required.

Ref. No.	Parts No.	Description	Schematic No.	Q'ty
FLYWHEEL BLOCK #13				
12-115x	800425	Flywheel Block Assy. Comp.	RDG #13	1
12-116	244506	Flywheel Only	RD-233	1
12-117x	244754	Felt, Flywheel	RD-275	1
12-118	251324	Main Metal Case	RD-236	1
12-119	253080	Main Metal	RD-237	1

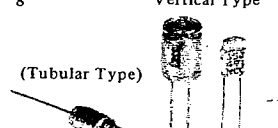
4. The symbol numbers shown on the P.C. Board list can be matched with the Composite Views of components of the Schematic Diagram or Service Manual.
5. The indications of Resistors and Capacitors in the photos of P.C. Board are being eliminated.
6. The shape of the parts and parts name, etc. can be confirmed by comparing them with the parts shown on the Electrical Parts Table of P.C. Board.
7. Both the kind of part and installation position can be determined by the Parts Number. To determine where a parts number is listed, utilize Parts Index at end of Parts List.
It is necessary first of all to find the Parts Number. This can be accomplished by using the Reference Number listed at right of parts number in the Parts Index. (meaning of ref. no. outlined in Item 3 above).
8. Utilize separate "Price List for Parts" to determine unit price. The most simple method of finding parts Price is to utilize the reference number.

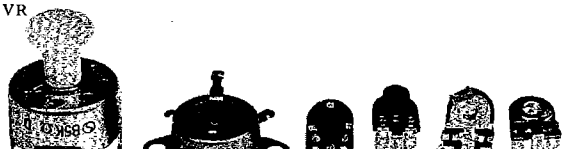
ELECTRICAL PARTS TABLE

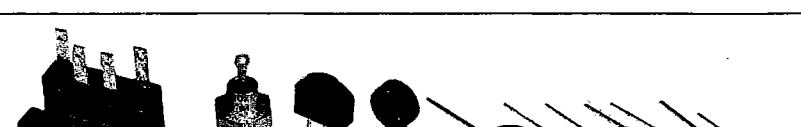
<p>Because the indication of resistors and capacitors in the P. C. Board photos are being eliminated, please confirm parts name and shape by comparing them with the parts shown in this table.</p>	1	2	3
	 Solid Resistor	Stopper Type  Insulator Type Carbon Resistor	 Metal Oxide Film Resistor
4	5	6	7
 Cement Resistor	 Wire-Wound Resistor	 Thermister	 Enamel Resistor
1	2	3	4
 MP Capacitor (Tubular Type)	 Plastic Capacitor	 Mylar Capacitor	 VFM (Hi-Q) Capacitor
5	6	7	8
 Mylar Capacitor	 Tantalum Capacitor	 Oil Capacitor (Tubular Type)	Vertical Type (Tubular Type)  Styrol Capacitor
9	10	11	12
 Electrolytic Capacitor (Tubular Type)	Vertical Type (Tubular Type)  Electrolytic Capacitor	 Ceramic Capacitor	 Metalized Mylar (Paper) Capacitor
13	VR		
 Trimmer Condenser	 Semi-Fixed Volume		
L	TR		
 Ferri Inductor	 Transistor		
CR	D		
 Spark Quencher	 Diode (Silicon, Zener, Germanium)		

**FIG. 1 ILLUSTRATION OF
HEAD BLOCK**

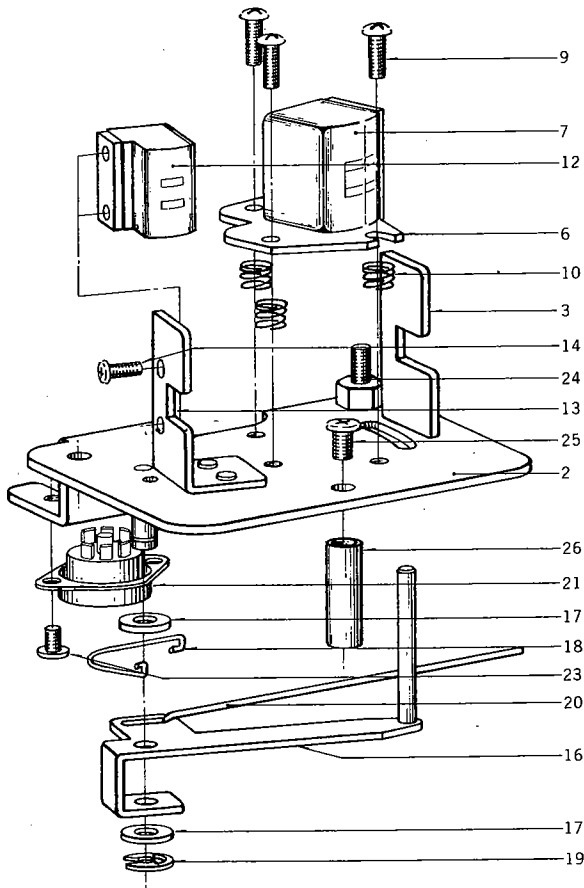

HEAD BLOCK

Ref. No.	Parts No.	Description	Schematic No.	Q'ty
1-1x	BH482051	4-TR-LC Head Block Comp.	LS-2, 3	1
1-2	HZ392501	Head Base, LS (s/pin)	LS-0001	1
1-3	HZ274195	Tape Guide No. 11	1630-19	2
1-4x	ZW273745	Spring Washer M3		2
1-5x	ZW601290	Nut M3		2
1-6	HZ392545	RH Angle Base	LS-0003	1
1-7	HP375131	REC./PB. HEAD P4-150		1
1-8x	ZS201508	Screw, pan head 2x4		2
1-9	ZS345914	Screw, round head 3x10		3
1-10	ZG382757	Angle Adjust Spring D	RD-A12	3
1-11x	HZ393974	I-MK Head Terminal Plate	RC-89	1
1-12	HE384693	ERASE HEAD E4-200		1
1-13	HZ410984	Erase Head Base	LF-0002	1
1-14	ZS201475	Screw, pan head 2x3		2
1-15x	ZS344283	Screw, pan head 3x4		2
1-16	HZ256432	Lifter Mt. Table B, w/pin	LM-4	1
1-17	ZW345442	Washer (Nylon) D4.2x9x1t		2
1-18	ZG389283	Tension Spring, LS	LS-0005	1
1-19	ZW290283	'U' Ring 2.85M	6-1-1	1
1-20	MZ301048	Lifter Spoke, 920	LM-12	1
1-21	EJ392567	Mold Socket SB-5202 (M Type)	31-1-75	1
1-22x	ZW273881	Earth Lug M4		1
1-23	ZS202061	Screw, binding head 3x5		3
1-24	ZS391588	Head Chassis Retaining Screw	LS-1001	1
1-25	ZS413201	Screw, pan head 4x8		2
1-26	HZ247511	Head Prop C	900-142	3

**FIG. 2 ILLUSTRATION OF
REEL TABLE BLOCK**

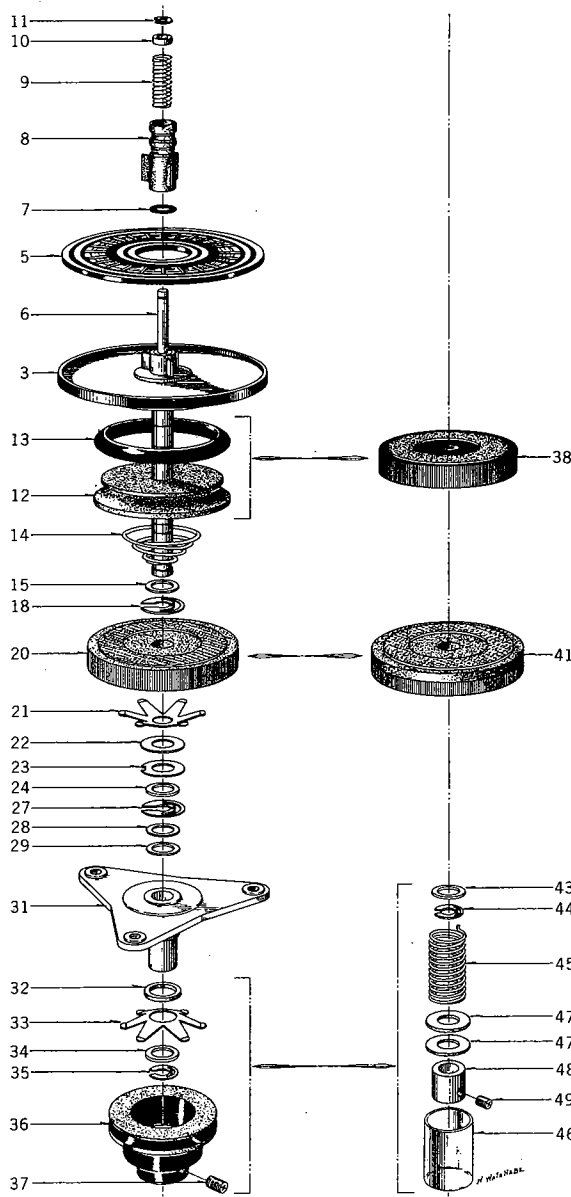

REEL TABLE BLOCK

Ref. No.	Parts No.	Description	Schematic No.	Qty
2-1x	BR570802	Supply Reel Table Block Comp.	LS-3	1
2-2x	BR570813	Take-up Reel Table Block Comp.	LS-3	1
2-3	MT255712	Reel Table Disk B, w/shaft A	XR-101	1
2-4x	MT252112	Friction Cloth B	900-225	1
2-5	MT376110	Reel Table Rubber, CD-2	CD-201	1
2-6	MS255600	Reel Shaft B	XR-103	1
2-7	MT297663	3R 'O' Ring 2.9x 1.65M	3R-139	1
2-8	MT255420	Reel Retainer	3R-102	1
2-9	ZG255683	Reel Spring	3R-109	1
2-10	MT255565	Reel Shaft Ring	XR-177	1
2-11	ZW270088	'E' Ring 1.9M	6-1-9	1
2-12	MR251460	Rewind Pulley	900-222	1
2-13	MT222366	Rubber Ring	900-234	1
2-14	ZG227553	Spring G-2 (Left)	900-230	1
2-15	ZW260021	Washer (SUP) D6.1x10x0.13t		3
2-16x	ZW260054	Washer (SUP) D6.1x10x0.25t		3
2-17x	ZW260065	Washer (SUP) D6.1x10x0.35t		3
2-18	MT255870	Reel Table Thrust Retainer Pin	900-237	1
2-19x	MT252101	Friction Cloth A	900-224	1
2-20	MR252066	Take-up Roller C	900-220	1
2-21	MT255971	Reel Table Spring Plate A	900-227	1
2-22	MT438647	Reel Torque Adjust Thrust 7 D6.2x13x0.5t	101022	1
2-23	ZW231693	Thrust Washer, w/claw	900-235	1
2-24	ZW260021	Washer (SUP) D6.1x10x0.13t		2
2-25x	ZW260054	Washer (SUP) D6.1x10x0.25t		2
2-26x	ZW260065	Washer (SUP) D6.1x10x0.35t		2
2-27	MT255870	Reel Table Thrust Retainer Pin	900-237	1
2-28	MT438592	Reel Torque Adjust Thrust 2 D6.1x10x0.3t	101017	1
2-29	MT438603	Reel Torque Adjust Thrust 3 D6.1x10x0.5t	101018	1
2-30x	MT438625	Reel Torque Adjust Thrust 5 D6.1x10x1t	101020	1
2-31	MT292386	Reel Metal Mt. Parts. XR (w/metal)	XR-191	1
2-32	ZW437804	Flywheel Thrust A D7.9x13x1t (Nylon)	101024	1
2-33	MT255993	Reel Table Spring Plate C	M8-207	1
2-34	ZW260065	Washer (SUP) D6.1x10x0.3t		1
2-35	MH270000	Retaining Pin D4	900-257	1
2-36	MR256094	Reel Table Pulley	900-239	1
2-37	ZS434171	Set Screw, hexagon socket 4x7 (Cup/p.)		1
2-38	MR252044	Take-up Roller A	900-218	1
2-39x	ZG227542	Spring G-2 (Right)	900-230	1
2-40x	MT255881	Reel Table Slip Plate A (Deer Skin)	MH-219	1
2-41	MR252077	Take-up Roller D (Lower)	M8-204	1
2-42x	MT255982	Reel Table Spring Plate B	900-228	1
2-43	MT438614	Reel Torque Adjust Thrust 4 D6.1x10x0.8t	101019	1
2-44	ZW312693	'E' Ring 4M	6-1-4	1
2-45	ZG414077	Spring F-4	CD-67	1
2-46	MT440313	Nylon Tube D12-L19		1
2-47	MT438636	Reel Torque Adjust Thrust 6 D6.2x13x1t	101021	1
2-48	MT228598	Set Sleeve B	CD-66	1
2-49	ZS434160	Set Screw, hexagon socket 3x3 (cup/p.)		1

FIG. 3 ILLUSTRATION OF MOTOR/BELT CHANGE LEVER BLOCK

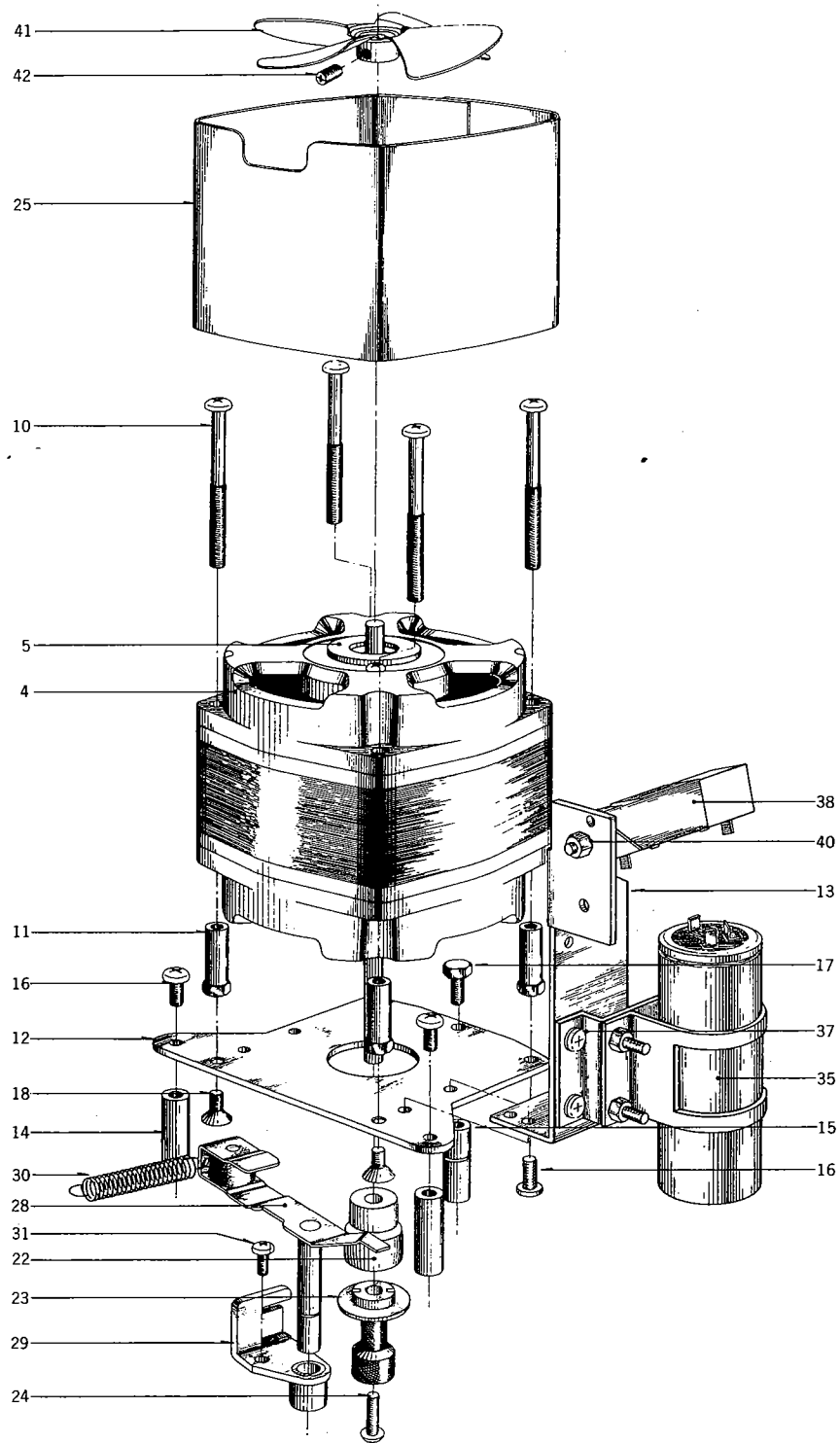

MOTOR/BELT CHANGE LEVER BLOCK

Ref. No.	Parts No.	Description	Schematic No.	Q'ty
MOTOR BLOCK				
3-1x	BM364320	Motor Block 16Y Comp.	LS-1,2,3	1
3-2x	BM486663	Motor Block 16Y Comp. (CSA)	LS-2,3	1
3-3x	BM489137	Motor Block 16Y Comp. (CEE)	LS-2,3	1
3-4	MZ448222	24 Motor Cover, w/metal	24X-781	2
3-5	MZ459178	24 Seal D	24X-786	1
3-6x	MZ458594	Oil Felt D	BS-7031	1
3-7x	MZ453598	24 Seal C	24X-785	1
3-8x	MZ458605	Oil Felt E	BS-7032	1
3-9x	ZS384131	Screw, round head 3x5		4
3-10	ZS427037	Screw, pan head 4x50, w/washer		4
3-11	MH254316	24 Motor Prop B	24X-729	4
3-12	MZ254373	Motor Mt. Plate L	24X-733	1
3-13	MZ430334	Motor/R. Table B	RC-112	1
3-14	MH254160	Motor Prop A	24X-730	2
3-15	MH254182	Motor Prop B	24X-731	1
3-16	ZS424056	Screw, pan head 4x10		4
3-17	ZS272395	Motor Prop Retaining Screw, M-7	24X-732	1
3-18	ZS427026	Screw, countersunk head 4x10		2
3-19x	MZ296144	24 Oil-cut	24X-735	2
3-20x	ZW222388	Rubber Washer	24X-739	1
3-21x	ZW259885	Washer (PBP) D5.1x10.3x0.1t		1
3-22	MR336172	Motor Pulley B, 24L	24X-775	1
3-23	MR257984	Knurling pulley, w/sleeve	24X-740C	1
3-24	ZS413921	Screw, oval countersunk bead 3x15		1
3-25	MZ254068	Motor Out-side Shield 2	3A-770C	1
3-26x	MZ292364	Motor Shield Plate B, XR (CSA, CEE)	XR-705	1
BELT CHANGE LEVER BLOCK				
3-27x	BL564107	Belt Change Lever Block (E) Comp.	LS-3	1
3-28	ML217462	Belt Change Lever B (small), w/roller	AT-25	1
3-29	MZ248354	Belt Guide Stop, w/metal	4TR-221	1
3-30	ZG465478	Brake Lever Spring	KD-1092	1
3-31	ZS417150	Screw, pan head 4x6		1
3-32x	ZG217394	Belt Change Spring B	MH-125	1
3-33x	ZW260054	Washer (SUP) D6.1x10x0.25t		1
3-34x	ZW290283	'U' Ring 2.85M	6-1-1	1
3-35	EC330401	MP/C. (Lug Type Uni/D.) 2+1μF 250WVAC	24-9-38	1
3-36x	EC486630	MP/C. (Lug Type Uni/D.) 2μF 250WVAC (UL, CSA)	24-9-64	1
3-37	ZS323728	Screw, binding head 3x5		2
3-38	ER339805	Cement/R, H20B 450(K)	35-16-16	1
3-39x	ZS413728	Screw, binding head 3x6 w/washer		1
3-40	ZW273756	Nut M3		1
3-41	MZ256882	Motor Fan D, w/boss	MH-636	1
3-42	ZS476987	Set Screw, hexagon socket 5x4 (cup/p.)		1

**FIG. 4 ILLUSTRATION OF
FLYWHEEL BLOCK**

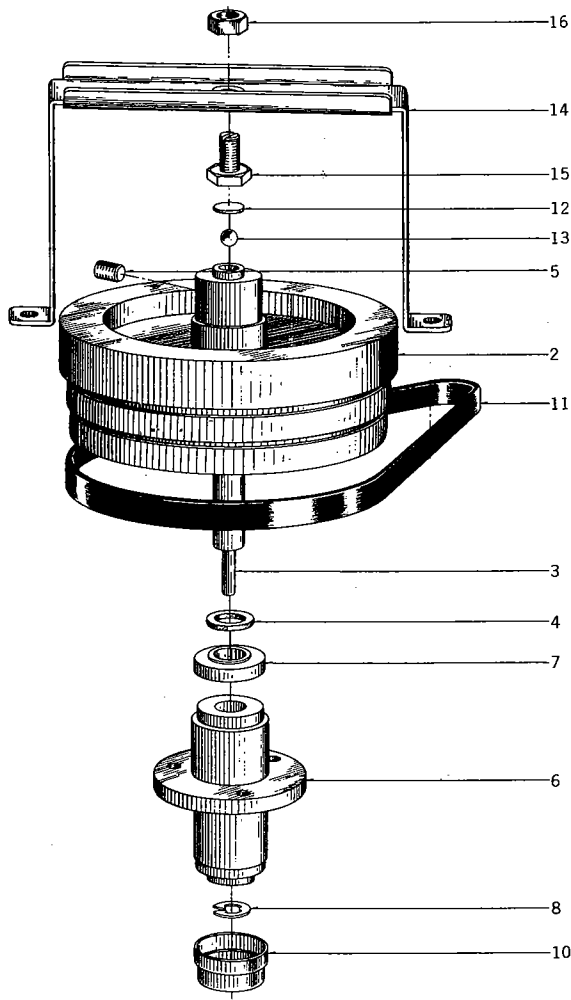

FLYWHEEL BLOCK

Ref. No.	Parts No.	Description	Schematic No.	Q'ty
4-1x	BF482040	Flywheel Block Comp.	LS-2, 3	1
4-2	MI296245	Flywheel 24	MH-202	1
4-3	MS481858	Main Shaft	LS-2201	1
4-4	ZW447208	Flywheel Thrust B D7.9x9x13x0.5t	101025	1
4-5	ZS373577	Set Screw, hexagon socket 5x6 (Flat/p.)		2
4-6	MZ413976	Main Case B 24 Comp.	1630-205	1
4-7	MZ446635	Thrust Cap, Main Metal B2	LF-2006	1
4-8	MH244710	Flywheel Fixing Pin	900-250	1
4-9x	MZ586438	Main Metal Cap Felt	A0414	1
4-10	MZ253113	Main Metal Cap B	MH-208	1
4-11	MB256590	Double Face Flat Belt D=110	100912	1
4-12	ZW392681	Washer (Nylon) D8x1t (without hole)		1
4-13	MV269965	Steel Ball D4		1
4-14	MZ585911	Shaft Supporting Plate	LS-1204	1
4-15	MZ585900	Shaft Support	LS-1203	1
4-16	ZW463410	ISO Nut #3 M5		1
4-17x	ZS419736	Screw, binding head 4x6		2

**FIG. 5 ILLUSTRATION OF
SWITCH BLOCK**

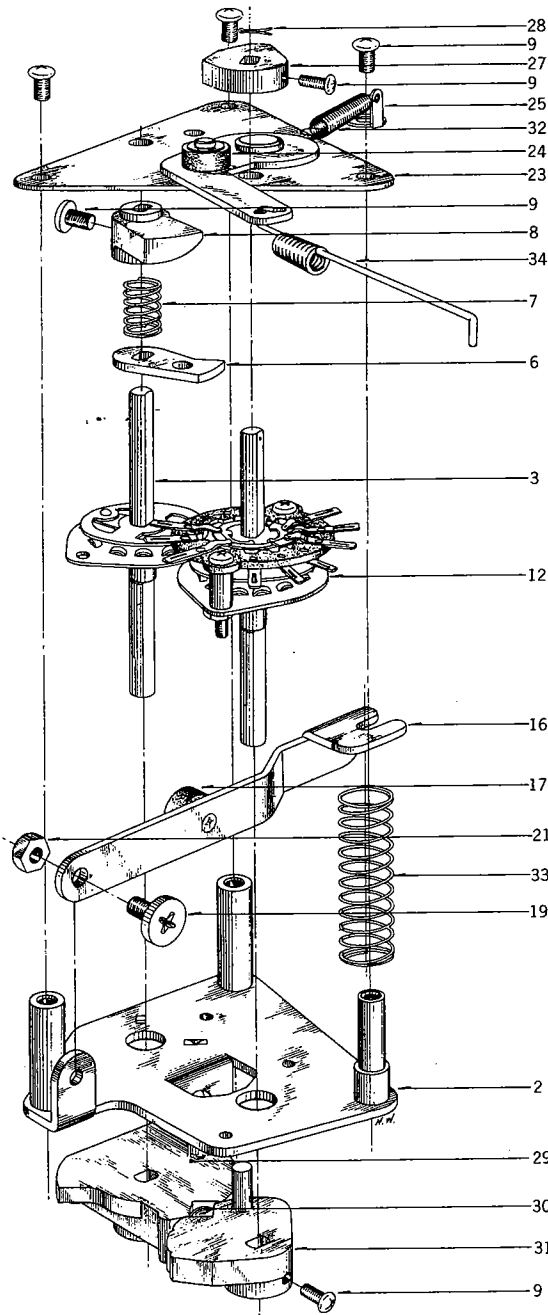

SWITCH BLOCK

Ref. No.	Parts No.	Description	Schematic No.	Qty
5-1x	BS601604	Switch Block Comp.	LS-1,2,3	1
5-2	MZ316901	SW. Table A-2, SX (w/props)	MR-201	1
5-3	ES601650	RWD Shaft, Y Type	25-8-10	1
5-4x	ZS413728	Screw, binding ehad 3x6, w/washer		2
5-5x	ZW260133	Washer (Fiber) D6.1x10x1t		2
5-6	MZ327341	Cap Trap Plate B	SX-201	1
5-7	ZG227586	Spring K	900-214	1
5-8	MZ327352	Cam C-2	SX-202	1
5-9	ZS413201	Screw, pan head 4x8		7
5-10x	ZW434193	Washer (Nylon) D6.1x10.3x0.5t		1
5-11x	ZW434215	Washer (Nylon) D6.1x10.3x0.3t		1
5-12	ES601672	Rotary SW. Y-133	25-7-42	1
5-13x	ZW273802	Toothed Lock Washer M3		2
5-14x	ZW273756	Nut M3		2
5-15x	MZ316945	Nut Plate	MR-245	1
5-16	ML257128	Lover I, w/shaft	900-209	1
5-17	MR217203	Cam Roller A (Nylon) D12	900-153	1
5-18x	ZW290283	'U' Ring 2.85M	6-1-1	2
5-19	ZS217877	Pause Lever Set Screw	900-136	1
5-20x	ZW571072	Washer (Nylon) D6.2x13x0.125t		1
5-21	ZW416698	Nut M4		1
5-22x	ZW273892	Toothed Lock Washer M4		1
5-23	MZ225720	SW. Table B-2, w/rec. lever	M9-308	1
5-24	MR217203	Cam Roller A (Nylon) D12	900-153	1
5-25	ZW273881	Earth Lug M4		1
5-26x	ZW260122	Washer (Nylon) D6.1x10x1t		1
5-27	MZ317068	Amp. SW. Cam B	MR-243	1
5-28	MH260425	Cotter Pin 1x10		1
5-29	MZ316956	Cam A-3	MR-242	1
5-30	MV270066	Steel Ball D8		1
5-31	MZ217271	Cam B (without tap)	900-206	1
5-32	ZG232121	Tension Lever Spring	MH-143	1
5-33	ZG227485	Spring E	900-119	1
5-34	ZG256937	Lever Spring	LCS-205	1
5-35x	MZ256814	Rewind Shaft Spacer	M9-124	2

MECH. ASSEMBLY BLOCK

Ref. No.	Parts No.	Description	Schematic No.	Q'ty	Ref. No.	Parts No.	Description	Schematic No.	Q'ty
TAPE GUIDE BLOCK					6-66x	ZW560801	Washer (Polyslider) D6.1x10x0.5t		2
6-1x	BZ400948	Tape Guide Block Comp.	LS-1,2,3	1	6-67	ZG205571	Idler Tension Spring	MH-135	1
6-2	MH204311	Tape Guide Prop #1700	AT-16	1	6-68	ZS413234	Screw, pan head 4x12		3
6-3	SZ465377	Tape Guide Table A	LC-618	1	6-69	MZ217708	Pause Lever Retaining Parts B	900-170	1
6-4	ZW231805	Tape Guide Washer (Large)	3A-356	2	6-70x	ZW260054	Washer (SUP) D6.1x10x0.25t		1
6-5	MV238117	Bearing SSR1950ZZSD52		1	6-71	MZ327251	G Lever Stopper, SX	SX-110	1
6-6	SZ465388	Tape Guide Table B	LC-619	1	6-72x	ZS349288	ISO Screw, binding head 3x5 w/washer		1
SPEED CHANGE BLOCK					6-73x	EJ373623	Pin Contact 61116-1	52-1-1	1
6-7x	BZ482062	Speed Change Block Comp.	LS-2, 3	1	6-74	MZ217113	Cam Stopper B	RC-129	1
6-8x	MZ481612	Speed SW. Retaining Plate	LS-2203	1	6-75	ZW217102	Cam Stopper Insulator Washer	900-165	1
6-9	ES479496	Slide SW. S-2	25-3-67	1	6-76	ZS413245	Screw, pan head 4x15		2
6-10x	ZS425981	ISO Screw, binding head 3x3		1	6-77	SB258478	Rec. Button (Red)	900-167	1
6-11x	ES481656	Slide SW. SSD02239	25-3-70	1	6-78x	ZW413256	Washer (SPC) D3.4x7.8x0.5t		1
6-12x	ZS481645	Screw, binding head 2.6x3		2	6-79x	ZW260436	Cotter Pin 1x12		1
6-13x	ML481768	Speed SW. Interlocking Lever	LS-2205	1	6-80	ML217934	Supply Brake Comp.	900-113	1
6-14x	ZS231298	Graduated Screw C	XR-514	1	6-81	MT245215	Brake Rubber (Large)	900-163	1
6-15x	HZ468281	Sensing Insulator Paper	BS-2086	1	6-82x	ZW259942	Washer (Fiber) D5.1x10.3x0.5t		3
MECH. ASSEMBLY BLOCK					6-83	ZG290384	JUN Spring D	1630-108	1
6-16	MZ392490	Mech. Frame, LS (w/bush)	LCS-27	1	6-84	ML251932	Take-up Brake Comp.	900-114	1
6-17	MH273295	Mech. Panel Prop, M-9	M9-302	2	6-85x	MT376457	Brake Rubber (Small)	M8-110	1
6-18x	ZS414033	Screw, countersunk head 3x8		2	6-86	ZG227452	Spring D	900-118	1
6-19	MS257051	Lever FA Shaft	900-127	1	6-87	ML548280	Lever LF, w/lever E2	LF-1013	1
6-20x	ZW413267	Flang Nut M4		2	6-88	ML300161	707 Lever A, w/metal	LC-103	1
6-21	MZ257073	Lever FB Guide Base	M9-103	1	6-89	ZW259918	Washer (SUP) D5.1x10.3x0.25t		2
6-22x	ZS417150	Screw, pan head 4x6		2	6-90x	ZS201767	Screw, pan head 4x6, w/washer		2
6-23	ZG257095	Lever FB Vibration Proof Spring	M8-104	1	6-91	ML262337	Lever C3	M8-106	1
6-24x	MH248343	Belt Guide Pin	4TR-109	1	6-92	ZG217337	Belt Return Spring	4TR-224	1
6-25	ZW413188	Nut M4		8	6-93	MZ260662	AS Lever Prop Base, w/prop	4TR-236	1
6-26	MS245463	Brake Lever Shaft	900-129	2	6-94	ZW273767	Earth Lug D3x20L		1
6-27x	MH245485	Brake Lever Pin (UL, CSA)	MH-138	1	6-95	MZ210071	Auto. SW Plate	M8-114	1
6-28x	ML308564	Belt Vibration Stopper (UL, CSA)	MH-137	1	6-96	ES479485	Slide SW. S-1	25-3-66	1
6-29x	MZ518973	Shut-off SW. Barrier (CSA)	LS-2207	1	6-97	ZS413166	Screw, round head 3x6		2
6-30	MS260515	A Lever Shaft	900-126	1	6-98	ML257040	Lever FA, w/shaft	900-107	1
6-31x	ZW273914	Spring Washer M4		2	6-99	MR217203	Cam Roller A (Nylon) D=12	900-153	1
6-32	EO606071	Hum Backing Coil 20T	23-3-40	2	6-100	ML295727	2-speed Motor Lever F, w/shaft	M8-107	1
6-33x	EO609862	Hum Backing Coil 30T (CEE)	23-3-41	2	6-101	ZG270358	F.B. Pull Spring	M8-108	1
6-34	MZ237418	Hum Backing Coil Metal Fitting (L Type)	M8-103	2	6-102	MI204423	Idler Wheel #2		1
6-35x	ZS432718	Screw, round head 3x22		2	6-103	ML257163	Lever K, w/shaft	900-111	1
6-36x	ZW273745	Spring Washer M3		2	6-104	ZG224796	New Spring D	MH-142	1
6-37x	ZW273756	Nut M3		2	6-105	ZW376391	Washer (Polyslider) D6.1x10x0.13t		1
6-38	ZS323728	Screw, binding head 3x5		6	6-106x	ZW432347	Washer (Luminar) D6.2x13x0.125t		2
6-39	ML226258	Start Lever A, w/lever C	4TR-122	1	6-107	ZS223233	Fulcrum Screw A	900-135	1
6-40	SB485741	Start Button C	MS-1002	1	6-108	ML231423	Middle Wheel	900-155	1
6-41	ZS425788	Screw, round head 3x4		2	6-109	ZW260122	Washer (Nylon) D6.1x10x1t		1
6-42	ES250007	Micro SW. M-8-3 U/L	25-1-6	1	6-110	ML492344	Pinch Roller Lever (Black)	900-161	1
6-43	MZ585887	Actuator B, w/pin lever	LS-1202	1	6-111	MS243404	Pinch Roller Shaft C	4TR-102	1
6-44	ZS417148	Screw, binding head 3x15		2	6-112x	ZW259975	Washer (SUP) D5.1x10.3x0.8t		1
6-45	ZS323728	Screw, binding head 3x5		5	6-113	MS582906	Cam Roller Shaft A-1	7-3-6	1
6-46x	ZW462835	Washer (PBP) D4.3x11x0.2t		1	6-114	MR269763	Cam Roller D=13	900-154	1
6-47x	ZW462846	Washer (PBP) D4.3x11x0.3t		1	6-115	ZG272981	Pinch Roller Spring, M-9	M9-104	1
6-48x	ZW330412	Adjust, Washer (U) D4x13x0.13t		1	6-116	ML369718	Pause Lever A, w/screw	RCC-101	1
6-49x	ZW330423	Adjust, Washer (U) D4x13x0.25t		1	6-117	ZS217877	Pause Lever Set Screw	900-136	1
6-50x	ZW330445	Adjust, Washer (U) D4x13x0.8t		1	6-118	MZ217855	Pause Stopper	900-169	1
6-51x	EJ205986	Cramp Terminal 2-SD	32-1-8	5	6-119	ZG217866	Pause Lever Spring A	900-123	1
6-52x	ZS413201	Screw, pan head 4x8		13	6-120	MZ217686	Pause Lever Cushion	LC-102	1
6-53x	MZ452496	Cycle Angle (CEE)	LS-1007	1	6-121	MZ293567	Head Lifter Cam A #1630	1630-104	1
6-54	ML475920	New Spring Hook	900-185	1	6-122	MZ293578	Head Lifter Cam B #1630	1630-105	1
6-55	ML309093	Lever B, w/lever D	900-103	1	6-123	MC216448	Counter MP-391-16 (w/base)	9-1-2	1
6-56	MR217203	Cam Roller A (Nylon) D=12	900-153	1	6-124x	MB406168	Counter Belt D123x1.8	3-3-14	1
6-57	MR217214	Cam Roller B (Steel) D=10.5	4TR-240	1	6-125	BL204658	AS Lever Comp. #2		1
6-58	ZW290283	'U' Ring 2.85M	6-1-1	13	6-126x	ZG294153	AS Lever Spring, 1700	AT-107	1
6-59	ZG469427	Spring B-1	LS-2004	1	6-127x	MP204794	Pinch Roller #3 D=40	3A-348	1
6-60	MZ253653	Metal Mt. Parts, w/metal	900-174	1	6-128x	EJ450573	Mate-N-Lock Cap Housing 9P 1-480277-0	52-1-7	1
6-61	ML270685	G Lever, w/H lever SX	900-109	1	6-129x	EJ373623	Pin Contact 61116-1	52-1-1	8
6-62	MS205560	Idler Shaft B	100150	3	6-130x	MZ229138	Wire Bundle Holder N-108	2-35-1	2
6-63	ZS200384	Screw, countersunk head 3x6		1	6-131	MZ301048	Lifter Spoke, 920	LM-12	1
6-64x	ZW260076	Washer (Nylon) D6.1x10x0.5t		1	6-132	ZG217394	Belt Change Spring B	MH-125	1
6-65	MI204423	Idler Wheel #2		1	6-133	MZ316956	Cam A-3	MR-242	1
					6-134	MV270066	Steel Ball D8		1
					6-135	MZ217271	Cam B (without Tap)	900-206	1
					6-136x	MZ605700	Frame Support A	LS-6228	1
					6-137x	MZ605711	Frame Support B	LS-6228	1

When ordering parts, please describe Parts Number, Serial Number, and Model Number in detail.

FIG. 6 ILLUSTRATION OF MECH. ASSEMBLY BLOCK

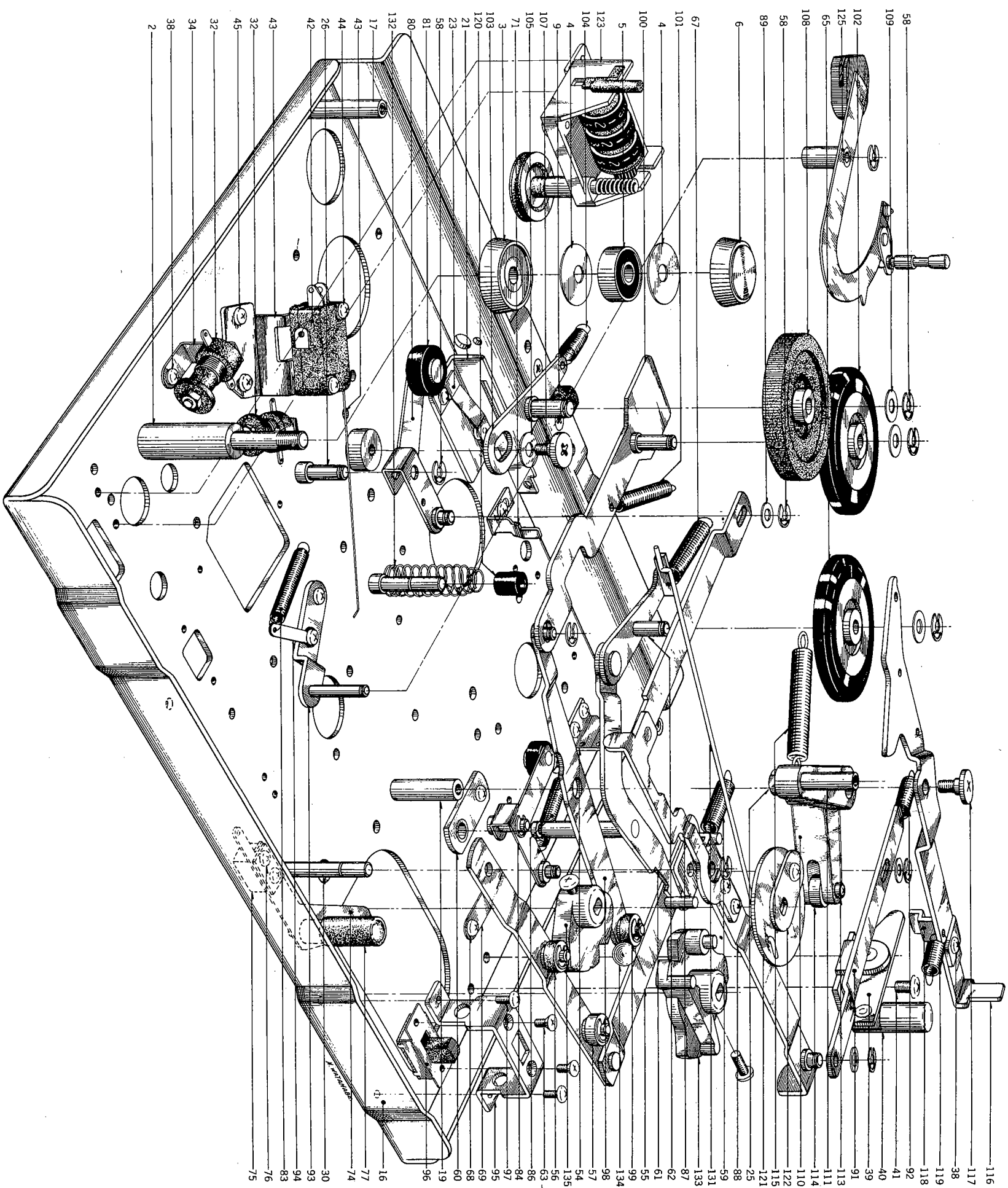
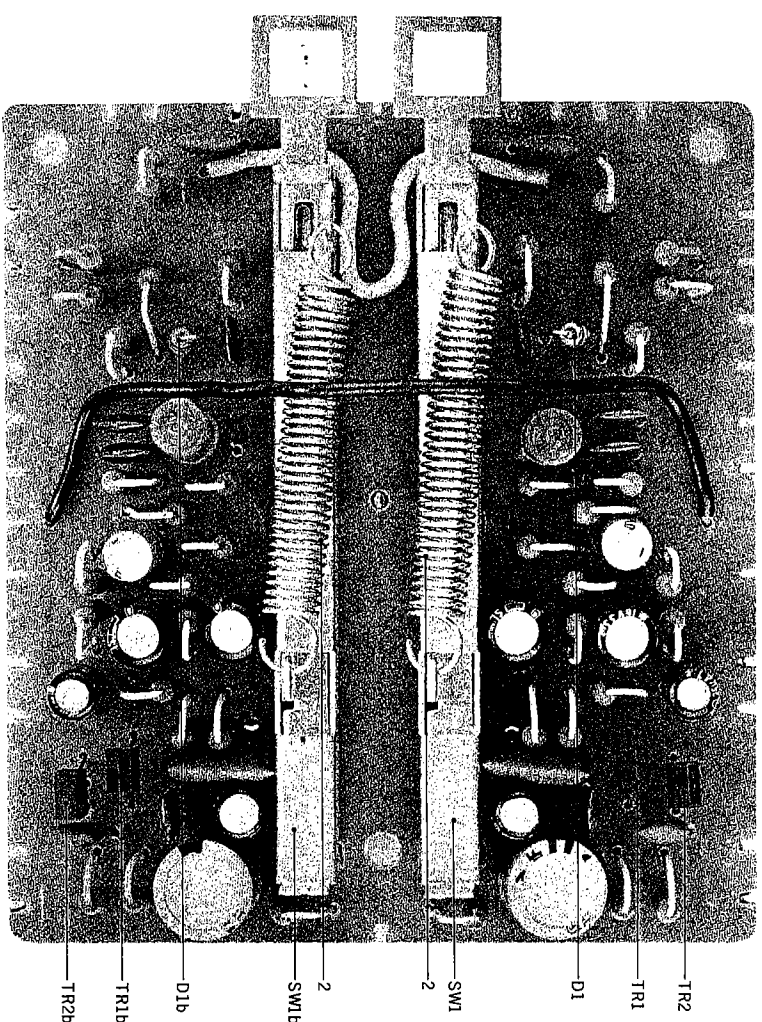

FIG. 7 PHOTO OF PRE-AMP. P.C. BOARD (LS-5209) BLOCK



PRE-AMP. P.C. BOARD (LS-5209) BLOCK

Symbol No.	Parts No.	Description	Qty	Symbol No.	Parts No.	Description	Qty
7-1x	BA4821117	PRE-AMP. P.C. Board Comp. (LS-5209)	1	7-R1, 2	ER211757	Resistor, Stopper Type	4
7-TR1	ET234843	Transistor 2SC458L(G)(B) (C)	2	7-R3	ER362485	Carbon RDI/4 330k(U)	2
7-TR2	ET234843	Transistor 2SC458L(G)(B) (C)	2	7-R4	ER336442	Carbon RDI/4 10k(U)	2
7-D1	ED219464	Germanium Diode 1N34A	2	7-R5	ER357412	Carbon RDI/4 220(U)	2
7-SW1	ES307877	Slide SW. CL162B35	2	7-R6	ER211757	Carbon RDI/4 100k(U)	2
7-2	ZG227441	Spring C	2	7-R7	ER212264	Carbon RDI/4 22k(U)	2
7-3x	EZ392095	Fasten Tab	3	7-R8	ER212883	Carbon RDI/4 4.7k(U)	2
				7-R9, 10	ER336442	Carbon RDI/4 10k(U)	4
				7-R11	ER349907	Carbon RDI/4 33k(U)	2
7-C1	EC220678	Capacitor, Vertical Type	2	7-R12	ER357570	Carbon RDI/4 150k(U)	2
7-C2	EC320051	Elect. 47µF 25WV	2	7-R13	ER306887	Carbon RDI/4 15k(U)	2
7-C3	EC336194	Elect. 10µF 16WV	2	7-R14	ER357456	Carbon RDI/4 2.2k(U)	2
7-C4	EC250604	VFM 270PF(U) 50WV	2	7-R15	ER399644	Carbon RDI/4 82(U)	2
7-C5	EC220590	Mylar 0.001µF(K) 50WV	2	7-R16	ER380913	Carbon RDI/4 33(U)	2
7-C6	EC220590	Elect. 33µF 10WV	2	7-R17	ER212477	Carbon RDI/4 3.3k(U)	2
7-C7	EC350616	VFM 50PF(U) 50WV	2	7-R18	ER357412	Carbon RDI/4 220(U)	2
7-C8	EC450527	Elect. 4.7µF 25WV	2	7-R19	ER213030	Carbon RDI/4 5.6k(U)	2
7-C9	EC487157	NP 0.47µF(M) 50WV	2	7-R20	ER213120	Carbon RDI/4 56(U)	2
7-C10	EC411827	Elect. 33µF 10WV	2				
7-C11	EC429851	EC411827	2				
7-C12	EC342821	VFM 680PF(U) 50WV	2				
7-C13	EC270573	Mylar 0.0068µF(K) 50WV	2				
7-C14	EC342821	FMS0PF(U) 500WV	2				
		Mylar 0.0068µF(K) 50WV	2				

FIG. 8 PHOTO OF MAIN AMP./OSC./POWER SUPPLY P.C. BOARD (LS-5207) BLOCK

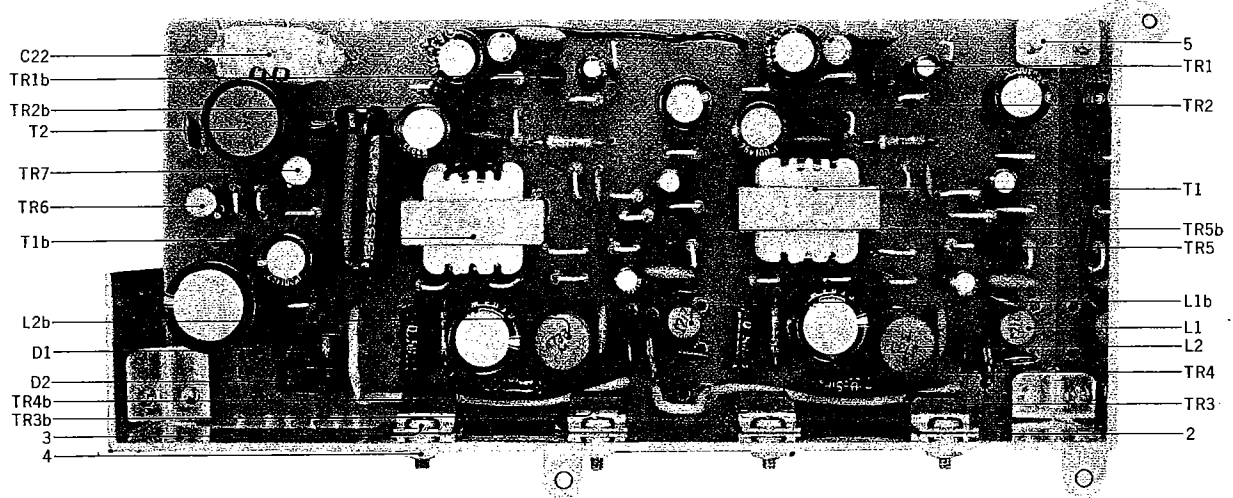

**MAIN AMP./OSC./POWER SUPPLY
P.C. BOARD (LS-5207) BLOCK**

Symbol No.	Parts No.	Description	Q'ty	Symbol No.	Parts No.	Description	Q'ty
8-1x	BA482128	Main Amp./OSC./Power Supply P.C. Board Comp. (LS-5207)	1	8-R1	ER342933	Resistor, Stopper Type Carbon RD1/4 27k(J)	2
8-TR1	ET539987	Transistor 2SC1312(F) (G)	2	8-R2	ER212883	Carbon RD1/4 4.7k(J)	2
8-TR2	ET379462	Transistor 2SC711(D) (E)	2	8-R3	ER212681	Carbon RD1/4 330(J)	2
8-TR3, 4	ET391735	Transistor 2SC1013(D) (E)	4	8-R4	ER391961	Carbon RD1/4 91k(J)	2
8-TR5	ET380834	Transistor 2SC711(E)	2	8-R5	ER363644	Carbon RD1/4 560(J)	2
8-TR6, 7	ET338894	Transistor 2SC968(3)	2	8-R6	ER350100	Carbon RD1/4 68k(J)	2
8-D1	ED329128	Silicon Diode 10DC-1(Red)	1	8-R7	ER211465	Carbon RD1/4 1k(J)	2
8-D2	ED329130	Silicon Diode 10DC-1(Black)	1	8-R8	ER392534	Carbon RD1/4 2k(J)	2
8-T1	BT390565	Driver Trans. N24-6847AT	2	8-R9	ER212016	Carbon RD1/4 150(J)	2
8-T2	EO383365	OSC. Coil OT-204	1	8-R10	ER371946	Carbon RD1/4 2k(J)	2
8-L1	EO383308	Ferri Inductor FL7H 2.7MH(J)	2	8-R11	ER212016	Carbon RD1/4 150(J)	2
8-L2	EO393423	Ferri Inductor FL11H 47MH(J)	2	8-R12, 13	ER251583	Wire-wound 1/2W 0.5(K) (L Type)	4
8-2	EZ481792	Heat-sink	1	8-R14	ER214402	Carbon RD1/4 470(J)	2
8-3	ZS321298	Screw, binding head 3x8	4	8-R15	ER336442	Carbon RD1/4 10k(J)	2
8-4	ZW273756	Nut M3	4	8-R16	ER350065	Carbon RD1/4 430(J)	2
8-5	ZS325495	Tapping Screw #2 3x6 (BR)	3	8-R17	ER450011	Carbon RD1/4 120k(J)	2
		Capacitor, Veritcal Type		8-R18	ER336442	Carbon RD1/4 10k(J)	2
8-C1	EC329850	VFM 220PF(J) 50WV	2	8-R19	ER306887	Carbon RD1/4 15k(J)	2
8-C2	EC320051	Elect. 10µF 16WV	2	8-R20	ER211465	Carbon RD1/4 1k(J)	2
8-C3	EC220465	Elect. 22µF 6.3WV	2	8-R21	ER212681	Carbon RD1/4 330(J)	1
8-C4	EC290520	VFM 100PF(J) 50WV	2	8-R22	ER251730	Wire-wound 3W 150(K) (L Type)	1
8-C5	EC350616	VFM 50PF(J) 50WV	2	8-R23, 24	ER399723	Carbon RD1/4 4.7(J)	2
8-C6	EC324516	Elect. 220µF 6.3WV	2	8-R25	ER212883	Carbon RD1/4 4.7k(J)	1
8-C7	EC220151	Elect. 100µF 25WV	2	8-R26	ER304402	Carbon RD1/4 470(J)	1
8-C8	EC220768	Elect. 470µF 10WV	2				
8-C9	EC320051	Elect. 10µF 16WV	2				
8-C10	EC450055	Elect. 1µF 25WV	2				
8-C11	EC329850	VFM 220PF(J) 50WV	2				
8-C12	EC411827	Mylar 0.0082µF(J) 50WV	2				
8-C13	EC451462	VFM 150PF(J) 50WV	2				
8-C14	EC389485	Mylar 0.018µF(J) 50WV	2				
8-C15	EC379157	Mylar 0.033µF(J) 50WV	2				
8-C16	EC424708	Mylar 0.0018µF(J) 50WV	2				
8-C17	EC220151	Elect. 100µF 25WV	2				
8-C18	EC450270	Elect. 1000µF 25WV	1				
8-C19	EC220151	Elect. 100µF 25WV	1				
8-C20, 21	EC250841	Mylar 0.01µF(J) 50WV	2				
8-C22	EC520481	Styrol 5500PF(J) 500WV	1				

FIG. 9 PHOTO OF AMP. ASSEMBLY BLOCK

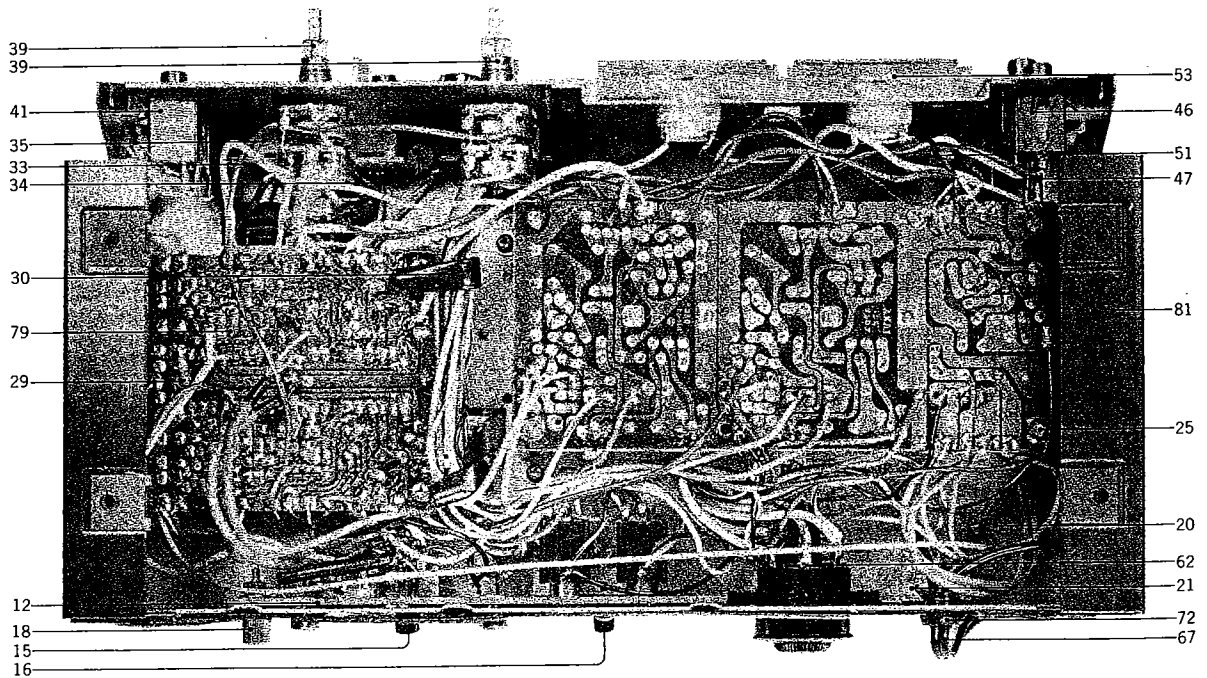
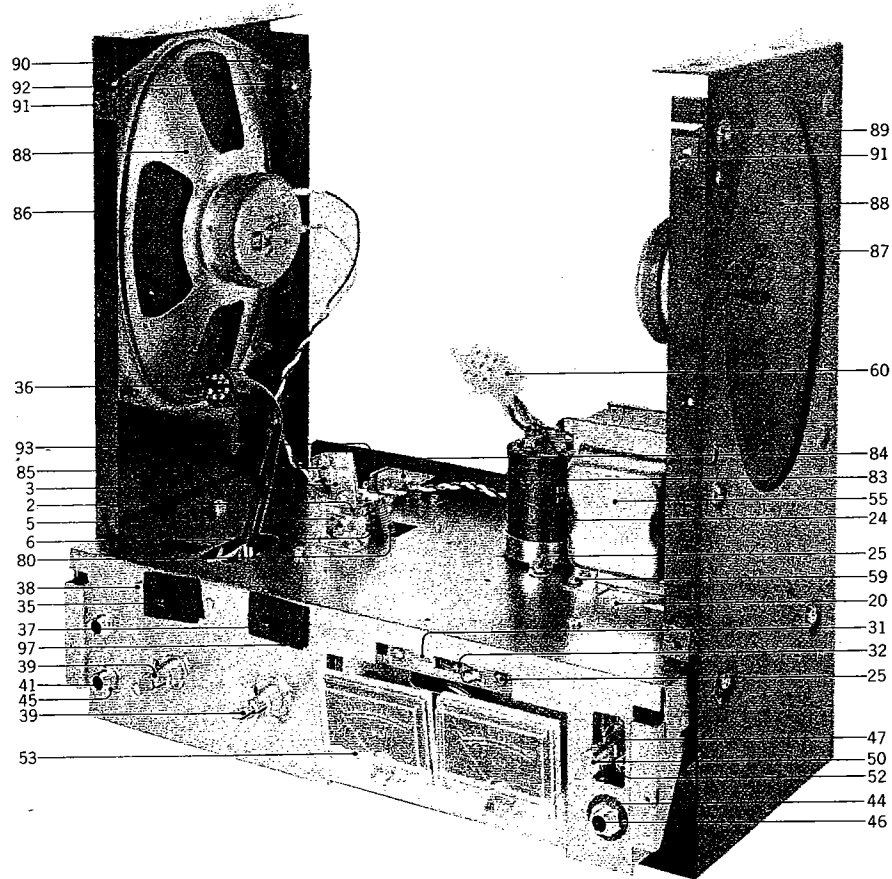

AMP. ASSEMBLY BLOCK

Ref. No.	Parts No.	Description	Schematic No.	Q'ty	Ref. No.	Parts No.	Description	Schematic No.	Q'ty
REC. LEVER BLOCK					9-58x	BT481702	Power Trans. LST-5 (CEE)	38-4-173	1
9-1x	BL482130	Rec. Lever Block Comp.	LS-2, 3	1	9-59	ZS200700	Tapping Screw #2 4x8 (Round)		4
9-2	ML294625	Rec. Lever 1, 1720	LCS-5	1	9-60	EJ300508	Mate-N-Lock Plug Housing 9P 1-480274-0	52-1-7	1
9-3	ML294636	Rec. Lever 2, 1720	LCS-7	1	9-61x	EJ373634	Socket Contact 61115-1	52-1-1	8
9-4x	ZS349288	Screw, binding head 3x5, w/washer		4	9-62	EJ233370	Socket (Volt. Selector) S-18010	40-2-3	1
9-5	EZ294434	1720 Shaft Hodler	LCS-6	1	9-63x	EF563681	Fuse 1A 250V	39-1-50	1
9-6	MS294513	Tension Arm Shaft, 1720	LCS-4	1	9-64x	ZS201183	ISO Screw, Truss Head 3x8 (Black)		2
9-7x	ZW273914	Spring Washer M4		1	9-65x	EJ254970	Lug Plate KP1L1	33-3-3	1
9-8x	NW273960	Nut M4		1	9-66x	EF460653	Fuse ST-1 1A (UL)	39-1-25	1
9-9x	ZW290283	'U' Ring 2.85M	6-1-1	1	9-67	EW540112	AC Cord (CUL) 2.5M	26-3-19	1
9-10x	MZ481825	SW. Interlocking Plate, 1720, (w/plate spring)	LS-5204	1	9-68x	EW354240	Power Cord (CEE) ER-0150		1
JACK PLATE BLOCK					9-69x	EW315448	Australia Cord (3 core)	26-3-11	1
9-11x	BJ482141	Jack Plate Block Comp.	LS-2, 3	1	9-70x	EW486797	Power Supply Cord (WG)	26-3-26	1
9-12	EJ481590	Jack Plate 1721, w/jack	LS-5205	1	9-71x	EJ585876	Fuse Terminal Plate 8 (CSA)	101061	1
9-13x	ER440921	Carbon/R. RD1/4 27k(J) (Insu. Type)	35-9-5	2	9-72	EZ382263	Strain Relief SR-4K-4	2-7-12	1
9-14x	ER443790	Carbon/R. RD1/4 470k(J) (Insu. Type)	35-9-5	2	9-73x	EZ246936	Strain Relief SR-6W-1 (WG, 3 core)	2-7-8	1
9-15	ES422436	Slide SW. SL-222B4C	25-3-40	1	9-74x	ZW392692	Washer, Strain Relief	LS-5017	11
9-16	ES481601	Slide SW. SL-243B4F	25-3-65	1	9-75x	ZW459134	Washer, Strian Relief (CEE)	LS-5027	1
9-17x	EJ486404	Terminal C (Nut)	LS-5218	1	9-76x	EJ585865	Fuse Holder (CEE)	101060	1
9-18	EJ457637	Terminal B (Screw)	55-5033	1	9-77x	EF354295	Fuse (T Type) 1.6AT (CEE)		1
9-19x	EZ328331	Fasten Receptacle 170043-2	52-1-8	4	9-78x	EF480903	Fuse 1A 125V (CSA)	39-1-44	1
AMP. ASSEMBLY BLOCK					9-79	BA482117	Pre-Amp. P.C. Board (LS-5209) Comp.	LS-5209	1
9-20	EZ481307	Amp. Chassis 1721	LS-5201	1	9-80	ZG250367	Micro Spring E	MH-22	1
9-21	ES317531	Slide SW. ESD-271DU	25-3-24	1	9-81	BA482128	Main Amp./Osc./Power Supply P.C. Board (LS-5207) Comp.	LS-5207	1
9-22x	ZW273881	Earth Lug M4		1	9-82x	EJ314403	Nylon Clip HP-2N (CEE)	2-7-36	1
9-23x	ZS200700	Tapping Screw #2 4x8 (Round)		1	9-83	EZ512122	SW. Retaining Plate	LS-5228	1
9-24	EC353766	Elect./C. 2200µF 25WV (Lug T (Lug Type)	24-10-47	1	9-84	ES422436	Slide SW. SL-222B4C	25-3-40	1
9-25	ZS325495	Tapping Screw #2 3x6 (BR)		11	9-85	ML294647	Rec. Lever 3, 1720	LCS-8	1
9-26x	EZ225077	Jack Plate Prop (Main Amp.)	LD-512	1	9-86	EZ293231	Speaker Mt. Chassis A, 1630 (Left)	1630-601	1
9-27x	ZS322626	Screw, binding head 3x8, w/washer		1	9-87	EZ293242	Speaker Mt. Chassis B, 1630 (Right)	1630-601	1
9-28x	MH481678	32 Prop (Pre-Amp.)	LCS-53	3	9-88	SS487168	Speaker 75E-8A	29-2-6	2
9-29	ZS413728	Screw, binding head 3x6, w/washer		1	9-89	ZS200496	Screw, countersunk head 4x12 (Black)		8
9-30	MZ259233	Wire Band C	3A-745	2	9-90	ZW413188	Nut #1 M4		8
9-31	EA390543	Pilot Lamp P.C. Board LS	LS-5016	1	9-91	ZW290248	Speed Nut (U Type) #1 M4 (Small)	6-3-1	4
9-32	EL390576	Pilot Lamp (L/T) RM6-24V-50MA	28-2-6	1	9-92	ZW290250	Speed Nut (U Type) #1 M4 (Large)	6-3-2	8
9-33	EA498958	SRTR SW. P.C. Board	LS-5226	1	9-93	SM481342	Jack Name Plate A	LS-6206, 7	1
9-34	EO392578	Ferri Inductor FL9H 200µH(K)	23-1-4	1	9-94x	SM481353	Jack Name Plate B (UL, CSA)	LS-6206, 8	1
9-35	ES368436	Slide SW. SL-243B4D	25-3-33	1	9-95x	SM481364	Jack Name Plate C (CEE)	LS-6206, 9	1
9-36	EJ390453	Connector Plug 7P S-17302	42-1-40	1	9-96x	ZS201150	Screw, truss head 3x6 (Black)		2
9-37	ES422436	Slide SW. SL-222B4C	25-3-40	1	9-97	SE449100	Mask B	BS-6012	2
9-38	ZS442585	Screw, binding head 2.6x4		4	9-98x	SE225977	SW. Mask (Nylon)	1630-605	1
9-39	EV390554	Double/Vol. D24N 50 kB+50kA	36-3-24	2					
9-40x	ER214290	Carbon/R. RD1/4 4.7k(J) (Insu. Type)	35-9-5	2					
9-41	EJ433844	Mic. Jack 2PMJ4	31-2-35	2					
9-42x	ER364948	Carbon/R. RD1/4 3.3k(J) (Insu. Type)	35-9-5	2					
9-43x	EZ225180	Nylon Collar, Jack	LD-520	2					
9-44	ZW455275	Washer (Fiber) D9.1x18x0.5t		3					
9-45	ZW391680	E Jack Nut	7-1-20	3					
9-46	EJ442078	Mic. Jack 3PMJ4	31-2-36	1					
9-47	ES246025	Push SW. SDF1PBP1 (UEH-12BP)	25-5-11	1					
9-48x	ES469541	Push SW. TV-3 JB52 (UL)	25-5-60	1					
9-49x	ES499972	Push SW. JS-09 (CEE, WG)	25-5-67	1					
9-50	SK569790	Push Button	LS-5230	1					
9-51	ER376413	Spark Quencher U/L 0.033µ+120Ω 500WV	41-1-37	1					
9-52	ZS442585	Screw, binding head 2.6x4		4					
9-53	EM476482	VU Meter D-1807R (18B Type)	46-1-54	2					
9-54x	SE446545	Mask A	DF-6041	2					
9-55x	BT390598	Power Trans. LST-1	38-4-101	1					
9-56x	BT390587	Power Trans. LST-2(UL)	38-4-102	1					
9-57x	BT481713	Power Trans. LST-4 (CSA)	38-4-172	1					

FIG. 10 PHOTO OF FINAL ASSEMBLY BLOCK



FINAL ASSEMBLY BLOCK

Ref. No.	Parts No.	Description	Schematic No.	Q'ty
FRONT PANEL BLOCK				
10-1x	SP570745	Front Panel Block Comp.	LS-3	1
10-2x	SP570756	Front Panel Block Comp. (UL,CSA,CEE)	LS-3	1
10-3	SP569766	Front Panel A 1722	LS-6219	1
10-4x	SP569777	Front Panel B 1722 (UL,CSA,CEE)	LS-6219	1
10-5	SC481487	Head Cover Base, 1721	LS-6203	1
10-6	ZS252426	Screw, truss head 3x6 (Without Groove)		2
10-7x	ZW273756	Nut M3		2
10-8	SE569788	Meter Escutcheon	LS-6220	2
10-9x	ZS524812	Screw, countersunk head 2x4		8
CASE BLOCK				
10-10	BC575695	Wood Case Block Comp.		1
10-11x	BC575706	Leather Case Block Comp.		1
10-12	SA377190	Rubber Foot, LM	LM-404	6
10-13x	ZW406247	Washer (SUP) D3.2x10x0.5t		6
10-14x	ZS202511	Screw, round head 3x18		6
10-15x	ZW345947	Tapping Screw #1 2.6x8 countersunk		8
10-16x	ZS316642	Wood Screw, countersunk head 2.4x6.3		8
10-17x	SE382217	Fan Grill	RD-A402	1
10-18	ZS324448	Tapping Screw #1 3x10 (Truss) (Black)		11
10-19	SE382228	Speaker Grill	RD-A403	2
10-20x	SZ237993	Hooking Holder B	100737	2
10-21x	SZ208271	Holder Metal Supporting Plate	CD-64	2
10-22x	ZW304536	Screw, oval countersunk head 3x14		2
10-23x	ZS203218	Wood Screw, round head 2.7x10		6
10-24x	SZ304964	Hooking #1 700	AT-37	2
10-25x	ZS202375	Screw, round head 3x10		2
10-26x	VM293883	Hinge #1700	AT-38	2
10-27x	SZ293477	Vinyl Handle #1630		1
10-28x	SZ324303	Handle Metal Fitting #1630		2
10-29x	SZ293455	Handle Metal Fitting Cover #1630		2
10-30x	ZS345971	Screw, countersunk head 4x35		2
FINAL ASSEMBLY BLOCK				
10-31x	SA377190	Rubber Foot, LM	LM-404	2
10-32x	ZS434283	Tapping Screw #1 4x30(Truss)		2
10-33x	ZW419646	Washer (SPC) D4.5x9.8x0.5t		2
10-34	SE569744	Knob Escutcheon	TD-6017	4
10-35	ZS570576	Screw, oval countersunk head 3x8		4
10-36	ZW408418	Panel Washer	KD-6029	4
10-37x	ZW273868	Cap Nut M3		1
10-38	SC481408	Head Cover, LS-II.	LS-6204	1
10-39	SM576551	Head Cover Name Plate 1722W	LS-6223	1
10-40x	SM576562	Head Cover Name Plate 1722L	LS-6223	1
10-41x	SC465761	Head Cover Shield Plate	LS-6018	1
10-42	ZS201150	Screw, truss head 3x6 (Black)		2
10-43	MP204794	Pinch Roller #3 D=40	3A-348	1
10-44	SK425158	Pinch Roller Cap	MS-6020	1
10-45x	ZW260201	Washer (Nylon) D6.2x13x1t		2
10-46x	ZW404010	Washer (BSP) D6.2x13x0.25t		2
10-47	SK476684	Mech. Knob	LE-6018	2
10-48x	ZS253405	Mech. Knob Screw	7-1-46	2
10-49	SK576606	Knob A (Black)	LE-6012	2
10-50	SK576573	Knob B (Black)	LE-6015	2
10-51x	ZW564118	Washer (Nylon) D11x18x0.8t		2
10-52x	EF563670	Fuse 0.5A 250V	39-1-50	1
10-53x	SZ327442	Cord Angle B	SX-405	2
10-54x	SZ476728	Cord Cover, M-9 (Roberts)	M9-435	2
10-55x	ZS481454	ISO Screw, truss head 3x12		2
10-56	SK314100	Pause Knob B	MR-612	1
10-57x	ZS433001	Set Screw, hexagon socket 3x5 (Cup/p.)		1
10-58x	EF563681	Fuse 1A 250V	39-1-50	1

INDEX

Parts No.	Ref. No. & Symbol No.	Parts No.	Ref. No. & Symbol No.	Parts No.	Ref. No. & Symbol No.	Parts No.	Ref. No. & Symbol No.	Parts No.	Ref. No. & Symbol No.
BA482117	7-1x	EJ373623	6-129x	ES481656	6-11x	MR217203	5-24	MZ317068	5-27
BA482117	9-79	EJ373634	9-61x	ES499972	9-49x	MR217203	6-56	MZ327251	6-71
BA482128	8-1x	EJ390453	9-36	ES601650	5-3	MR217203	6-99	MZ327341	5-6
BA482128	9-81	EJ392567	1-21	ES601672	5-12	MR217214	6-57	MZ327352	5-8
BC575695	10-10	EJ433844	9-41	ET234843	7-TR1	MR251460	2-12	MZ392490	5-16
BC575706	10-11x	EJ442078	9-46	ET234843	7-TR2	MR252044	2-38	MZ413976	4-6
BF482040	4-1	EJ450573	6-128x	ET338894	8-TR6, 7	MR252066	2-20	MZ430334	3-13
BH482051	1-1x	EJ457637	9-18	ET379462	8-TR2	MR252077	2-41	MZ446635	4-7
BJ482141	9-11x	EJ481590	9-12	ET380834	8-TR5	MR256094	2-36	MZ448222	3-4
BL204658	6-125	EJ486404	9-17x	ET391735	8-TR3, 4	MR257984	3-23	MZ452496	6-53x
BL482130	9-1x	EJ585865	9-76x	EV539987	8-TR1	MR269763	6-114	MZ453598	3-7x
BL564107	3-27x	EJ585876	9-71x	EV390554	9-39	MR336172	3-22	MZ458594	3-6x
BM364320	3-1x	EL390576	9-32	EW315448	9-69x	MS205560	6-62	MZ458605	3-8x
BM486663	3-2x	EM476482	9-53	EW354240	9-68x	MS243404	6-111	MZ459178	3-5
BM489137	3-3x	EO383308	8-L1	EW486797	9-70x	MS245463	6-26	MZ481612	6-8x
BR570802	2-1x	EO383365	8-T2	EW540112	9-67	MS255600	2-6	MZ481825	9-10x
BR570813	2-2x	EO392578	9-34	EZ225077	9-26x	MS257051	6-19	MZ518973	6-29x
BS601604	5-1x	EO393423	8-L2	EZ225180	9-43x	MS260515	6-30	MZ585887	6-43
BT390565	8-T1	EO606071	6-32	EZ246936	9-73x	MS294513	9-6	MZ885900	4-15
BT390587	9-56x	EO609862	6-33x	EZ293231	9-86	MS481858	4-3	MZ585911	4-14
BT390598	9-55	ER211465	8-R7	EZ293242	9-87	MS582906	6-113	MZ586438	4-9x
BT481702	9-58x	ER211465	8-R20	EZ294434	9-5	MT222366	2-13	MZ605700	6-136x
BT481713	9-57x	ER211757	7-R1, 2	EZ328331	9-19x	MT228598	2-48	MZ605711	6-137x
BZ400948	6-1x	ER211757	7-R6	EZ382263	9-72	MT245215	6-81	SA377190	10-12
BZ482062	6-7x	ER212016	8-R9	EZ392095	7-3x	MT252101	2-19x	SA377190	10-31x
EA390543	9-31	ER212016	8-R11	EZ481307	9-20	MT252112	2-4x	SB258478	6-77
EA498958	9-33	ER212264	7-R7	EZ481792	8-2	MT255420	2-8	SB485741	6-40
EC220151	8-C7	ER212477	7-R17	EZ512122	9-83	MT255565	2-10	SC465761	10-41x
EC220151	8-C17	ER212681	8-R3	HE384693	1-12	MT255712	2-3	SC481408	10-38
EC220151	8-C19	ER212681	8-R21	HP375131	1-7	MT255870	2-18	SC481487	10-5
EC220465	8-C3	ER212883	7-R8	HZ247511	1-26	MT255870	2-27	SE225977	9-98x
EC220590	7-C5	ER212883	8-R2	HZ256432	1-16	MT255881	2-40x	SE382217	10-17x
EC220590	7-C7	ER212883	8-R25	HZ274195	1-3	MT255971	2-21	SE382228	10-19
EC220678	7-C1	ER213030	7-R19	HZ392501	1-2	MT255982	2-42x	SE446545	9-54
EC220768	8-C8	ER213120	7-R20	HZ392545	1-6	MT255993	2-33	SE449100	9-97x
EC250604	7-C4	ER214290	9-40x	HZ393974	1-11x	MT292386	2-31	SE569744	10-34
EC250841	8-C20, 21	ER214402	8-R14	HZ410984	1-13	MT297663	2-7	SE569788	10-8
EC270573	7-C13	ER251583	8-R12, 13	HZ468281	6-15x	MT376110	2-5	SK314100	10-56
EC290520	8-C4	ER251730	8-R22	MB256590	4-11	MT376457	6-85x	SK425158	10-44
EC320051	7-C2	ER304402	8-R26	MB406168	6-124x	MT438592	2-28	SK476684	10-47
EC320051	8-C2	ER306887	7-R13	MC216448	6-123	MT438603	2-29	SK569790	9-50
EC320051	8-C9	ER306887	8-R19	MH204311	6-2	MT438614	2-43	SK576573	10-50
EC324516	8-C6	ER336442	7-R4	MH244710	4-8	MT438625	2-30x	SK576606	10-49
EC329850	8-C1	ER336442	7-R9, 10	MH245485	6-27x	MT438636	2-47	SM481342	9-93
EC329850	8-C11	ER336442	8-R15	MH248343	6-24x	MT438647	2-22	SM481353	9-94x
EC330401	3-35	ER336442	8-R18	MH254160	3-14	MT440313	2-46	SM481364	9-95x
EC336194	7-C3	ER339805	3-38	MH254182	3-15	MV248117	6-5	SM576551	10-39
EC342821	7-C12	ER342933	8-R1	MH254316	3-11	MV269965	4-13	SM576562	10-40x
EC342821	7-C14	ER349907	7-R11	MH260425	5-28	MV270066	5-30	SP569766	10-3
EC350616	7-C6	ER350065	8-R16	MH270000	2-35	MV270066	6-134	SP569777	10-4x
EC350616	8-C5	ER350100	8-R6	MH273295	6-17	MZ210071	6-95	SP570745	10-1x
EC353766	9-24	ER357412	7-R5	MH481678	9-28x	MZ217113	6-74	SP570756	10-2x
EC379157	8-C15	ER357412	7-R18	MI204423	6-65	MZ217271	5-31	SS487168	9-88
EC389485	8-C14	ER357456	7-R14	MI204423	6-102	MZ217271	6-135	SZ208271	10-21x
EC411827	7-C10	ER357570	7-R12	MI231423	6-108	MZ217686	6-120	SZ237993	10-20x
EC411827	8-C12	ER362485	7-R3	MI296245	4-2	MZ217708	6-69	SZ293455	10-29x
EC424708	8-C16	ER363644	8-R5	ML217462	3-28	MZ217855	6-118	SZ293477	10-27x
EC429851	7-C11	ER364948	9-42x	ML217934	6-80	MZ225720	5-23	SZ304964	10-24x
EC450055	8-C10	ER371946	8-R10	ML226258	6-39	MZ229138	6-130x	SZ324303	10-28x
EC450270	8-C18	ER376413	9-51	ML251932	6-84	MZ237418	6-34	SZ327442	10-53x
EC450527	7-C8	ER380913	7-R16	ML257040	6-98	MZ248354	3-29	SZ465377	6-3
EC451462	8-C13	ER391961	8-R4	ML257128	5-16	MZ253113	4-10	SZ465388	6-6
EC486630	3-36x	ER392534	8-R8	ML257163	6-103	MZ253653	6-60	SZ476728	10-54x
EC487157	7-C9	ER399644	7-R15	ML262337	6-91	MZ254068	3-25	VM293883	10-26x
EC520481	8-C22	ER399723	8-R23, 24	ML270685	6-61	MZ254373	3-12	ZG205571	6-67
ED219464	7-D1	ER440921	9-13x	ML294625	9-2	MZ256814	5-35x	ZG217337	6-92
ED329128	8-D1	ER443790	9-14x	ML294636	9-3	MZ256882	3-41	ZG217394	3-32x
ED329130	8-D2	ER450011	8-R17	ML294647	9-85	MZ257073	6-21	ZG217394	6-132
EF354295	9-77x	ES246025	9-47	ML295727	6-100	MZ259233	9-30	ZG217866	6-119
EF460653	9-66x	ES250007	6-42	ML300161	6-88	MZ260662	6-93	ZG224796	6-104
EF480903	9-78x	ES307877	7-SW1	ML308564	6-28x	MZ292364	3-26x	ZG227441	7-2
EF563670	10-52x	ES317531	9-21	ML309093	6-55	MZ293567	6-121	ZG227452	6-86
EF563681	9-63x	ES368436	9-35	ML369718	6-116	MZ293578	6-122	ZG227485	5-33
EF563681	10-58x	ES422436	9-15	ML475920	6-54	MZ296144	3-19x	ZG227542	2-39x
EJ205986	6-51x	ES422436	9-37	ML481768	6-13x	MZ301048	6-131	ZG227553	2-14
EJ233370	9-62	ES422436	9-84	ML492344	6-110	MZ301048	1-20	ZG227586	5-7
EJ254970	9-65x	ES469541	9-48x	ML548280	6-87	MZ316901	5-2	ZG232121	5-32
EJ300508	9-60	ES479485	6-96	MP204794	6-127x	MZ316945	5-15x	ZG250367	9-80
EJ314403	9-82x	ES479496	6-9	MP204794	10-43	MZ316956	5-29	ZG255633	2-9
EJ373623	6-73x	ES481601	9-16	MR217203	5-17	MZ316956	6-133	ZG256937	5-34

INDEX

Part No.	Ref. No. & Symbol No.	Part No.	Ref. No. & Symbol No.	Part No.	Ref. No. & Symbol No.	Part No.	Ref. No. & Symbol No.	Part No.	Ref. No. & Symbol No.
ZG257095	6-23	ZW217102	6-75	ZW571072	5-20x				
ZG270358	6-101	ZW222388	3-20x	ZW601290	1-5x				
ZG272981	6-115	ZW231693	2-23						
ZG290384	6-83	ZW231805	6-4						
ZG294153	6-126x	ZW259885	3-21x						
ZG382757	1-10	ZW259918	6-89						
ZG389283	1-18	ZW259942	6-82x						
ZG414077	2-45	ZW259975	6-112x						
ZG465478	3-30	ZW260021	2-15						
ZG469427	6-59	ZW260021	2-24						
ZS200384	6-63	ZW260054	2-16x						
ZS200496	9-89	ZW260054	2-25x						
ZS200700	9-23x	ZW260054	3-33x						
ZS200700	9-59	ZW260054	6-70x						
ZS201150	9-96x	ZW260065	2-17x						
ZS201150	10-42	ZW260065	2-26x						
ZS201183	9-64x	ZW260065	2-34						
ZS201475	1-14	ZW260076	6-64x						
ZS201508	1-8x	ZW260122	5-26x						
ZS201767	6-90x	ZW260122	6-109						
ZS202061	1-23	ZW260133	5-5x						
ZS202375	10-25	ZW260201	10-45x						
ZS202511	10-14x	ZW260436	6-79x						
ZS203218	10-23x	ZW270088	2-11						
ZS217877	5-19	ZW273745	1-4x						
ZS217877	6-117	ZW273745	6-36x						
ZS223233	6-107	ZW273756	3-40						
ZS231298	6-14x	ZW273756	5-14x						
ZS252426	10-6	ZW273756	6-37x						
ZS253405	10-48x	ZW273756	8-4						
ZS272395	3-17	ZW273756	10-7x						
ZS316642	10-16x	ZW273767	6-94						
ZS321298	8-3	ZW273802	5-13x						
ZS322626	9-27x	ZW273868	10-37x						
ZS323728	3-37	ZW273881	1-22x						
ZS323728	6-38	ZW273881	5-25						
ZS323728	6-45	ZW273881	9-22x						
ZS324448	10-18	ZW273892	5-22x						
ZS325495	8-5	ZW273914	6-31x						
ZS325495	9-25	ZW273914	9-7x						
ZS344283	1-15x	ZW273960	9-8x						
ZS345914	1-9	ZW290248	9-91						
ZS345971	10-30x	ZW290250	9-92						
ZS349288	6-72x	ZW290283	1-19						
ZS349288	9-4x	ZW290283	3-34x						
ZS373577	4-5	ZW290283	5-18x						
ZS384131	3-9x	ZW290283	6-58						
ZS391588	1-24	ZW290283	9-9x						
ZS413166	6-97	ZW304536	10-22x						
ZS413201	1-25	ZW312693	2-44						
ZS413201	5-9	ZW330412	6-48x						
ZS413201	6-52x	ZW330423	6-49x						
ZS413234	6-68	ZW330445	6-50x						
ZS413245	6-76	ZW345442	1-17						
ZS413728	3-39x	ZW345947	10-15x						
ZS413728	5-4x	ZW376391	6-105						
ZS413728	9-29	ZW391680	9-45						
ZS413921	3-24	ZW392681	4-12						
ZS414033	6-18x	ZW392692	9-74x						
ZS417148	6-44	ZW404010	10-46x						
ZS417150	3-31	ZW406247	10-13x						
ZS417150	6-22x	ZW408418	10-36						
ZS419736	4-17x	ZW413188	6-25						
ZS424056	3-16	ZW413188	9-90						
ZS425788	6-41	ZW413256	6-78x						
ZS425981	6-10x	ZW413267	6-20x						
ZS427026	3-18	ZW416698	5-21						
ZS427037	3-10	ZW419646	10-33x						
ZS432718	6-35x	ZW432347	6-106x						
ZS433001	10-57x	ZW434193	5-10x						
ZS434160	2-49	ZW434215	5-11x						
ZS434171	2-37	ZW437804	2-32						
ZS434283	10-32x	ZW447208	4-4						
ZS442585	9-38	ZW455275	9-44						
ZS442585	9-52	ZW459134	9-75x						
ZS476987	3-42	ZW462835	6-46x						
ZS481454	10-55x	ZW462846	6-47x						
ZS481645	6-12x	ZW463410	4-16						
ZS524812	10-9x	ZW560801	6-66x						
ZS570576	10-35	ZW564118	10-51x						

SECTION 3

SCHEMATIC DIAGRAM

1. 1722W SCHEMATIC DIAGRAM
2. 1722L SCHEMATIC DIAGRAM

1722W/L

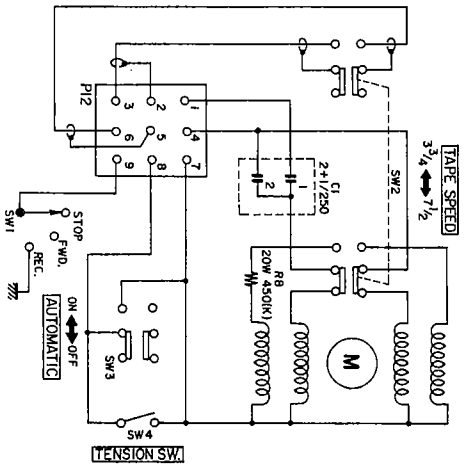

WG 1722W(L)

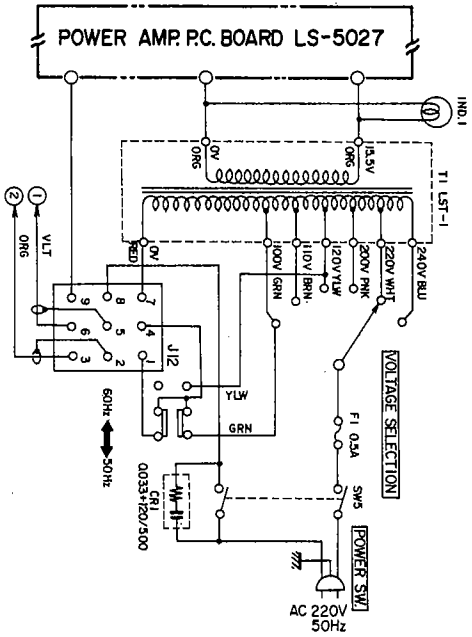

1722W/L

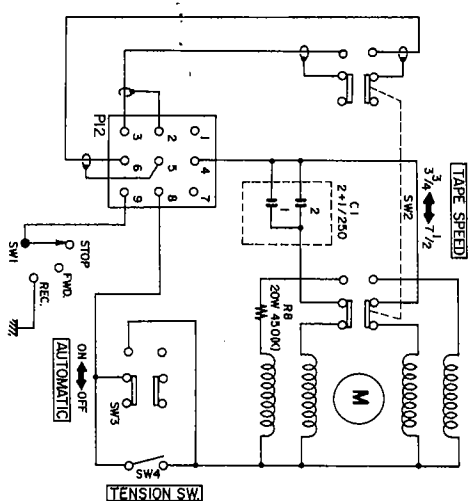

CEE 1722W(L)

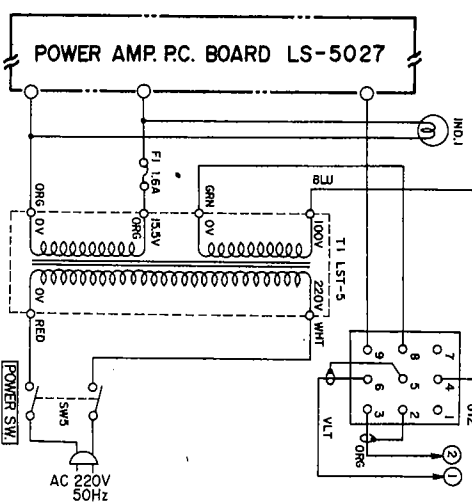

AAL 1722W

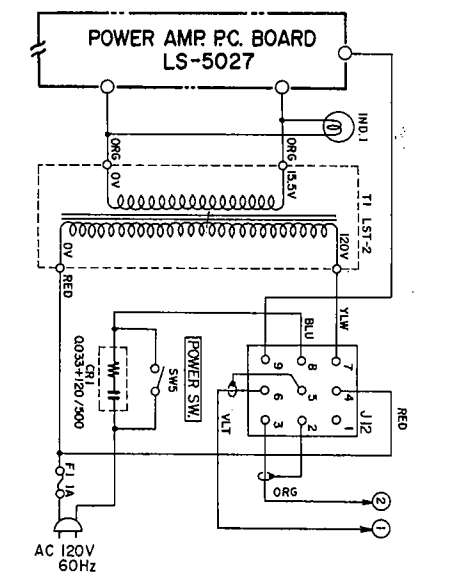
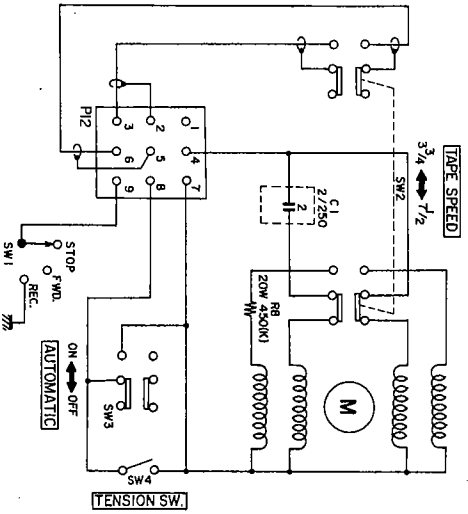

CSA 1722W

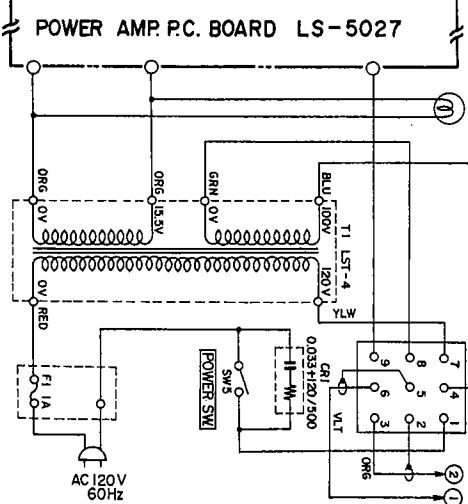
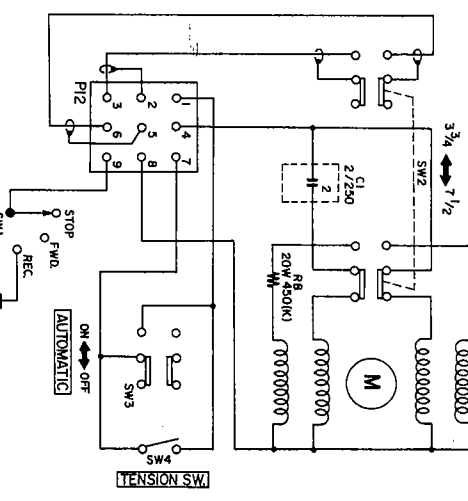

1

2

3

4

5

1

1

1

1

1